

# PROGRAMMABLE KEYBOARD AND COMM CONTROLLER (PKCC) SCN2671

## DESCRIPTION

The Signetics 2671 Programmable Keyboard and Communications Controller (PKCC) is an MOS LSI device which provides a versatile keyboard encoder and an independent full duplex asynchronous communications controller. It is intended for use in microprocessor based systems and provides an eight bit data bus interface.

The keyboard encoder handles the scanning, debounce, and encoding of a keyboard matrix with a maximum of 128 keys. It provides four levels of key encoding corresponding to the separate SHIFT and CONTROL input combinations. Four keyboard rollover modes can be programmed including provisions for up to 16 latched keys. Control outputs are provided for interfacing with contact or capacitive keyboards. An eight bit keyboard status register provides status information to the CPU.

The receiver section of the communications controller accepts serial data from the RxD pin and converts it to parallel data characters. Simultaneously, the transmitter section accepts parallel data from the data bus and outputs serialized data onto the TxD pin. Received data is checked for parity and framing errors, and break conditions are flagged. Character lengths can be programmed as 5, 6, 7, or 8 bits not including parity, start or stop bits. An internal baud rate generator (BRG) with 16 divider ratios can be used to derive the receive and/or transmit clocks. The BRG can accept an external clock or operate directly from a crystal. An eight bit communications status register provides status information to the CPU.

The PKCC has an interrupt mask register to selectively enable certain keyboard and communications status bits to generate interrupts. Priority encoded interrupt vectoring is available. Upon receipt of an interrupt acknowledge, an interrupt vector will be output on D0-D7 reflecting the source of the interrupt. The interrupt source can also be read from an interrupt status register.

## FEATURES

- **Keyboard interface**
  - Contact or capacitive keyboard
  - Up to 128 keys on an 8 X 16 matrix
  - Encoded or unencoded operation
  - Four code levels per key
  - Latched key option—separate depress and release codes
  - Programmable scan rate and debounce time
  - Programmable rollover modes
  - Programmable auto-repeat for selected keys
  - Tone output—two frequencies
- **Asynchronous communication interface**
  - Internal baud rate generator—16 rates
  - Full duplex operation
  - Detection of start and end of break
  - Programmable break generation
  - Programmable character parameters
  - Auto-echo and maintenance loopback modes
- **Polled or interrupt operation**
- **Interrupt priority controller and vector generator**
- **Operates directly from crystal or external clocks**
- **TTL compatible**
- **Single +5 volt power supply**
- **40 pin dual in-line package**

## APPLICATIONS

- CRT terminals
- Hard copy terminals
- Word processing systems
- Data entry terminals
- Small business computers

## FUNCTIONAL DESCRIPTION

The PKCC consists of six major sections (see block diagram). These are the transmitter, receiver, timing, operation control, keyboard encoder, and a priority encoded interrupt control unit. These sections communicate with each other via an internal data bus and an internal control bus. The internal data bus interfaces to the microprocessor data bus via a bidirectional data bus buffer.

## PIN CONFIGURATION

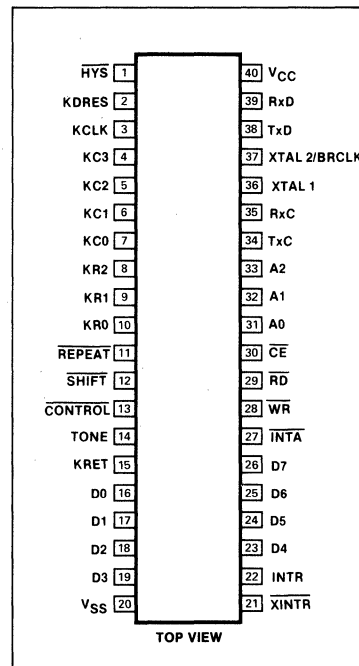

## Operation Control

This functional block stores configuration and operation commands from the CPU and generates appropriate signals to various internal sections to control the overall device operation. It contains read and write circuits to permit communications with the microprocessor via the data bus and contains mode registers KMR and CMR, the command decoder, and status registers KSR and CSR. Details of operating modes and status information are presented in the Operation section of this data sheet. The register addressing is specified in table 1.

## Timing

The PKCC contains a baud rate generator (BRG) which is programmable to accept external transmit or receive clocks or to divide an external clock to perform data communications. The unit can generate 16 baud rates, any of which can be selected for full duplex operation. The external clock to the baud rate generator can be applied directly to the XTAL2 input (see figure 21) or can be generated internally by connecting a crystal across the XTAL1, XTAL2 input pins. The clock input is also utilized by the keyboard encoder section. Thus, a clock must be provided even if external transmitter and receiver clocks are used.

## ORDERING CODE

PACKAGES	COMMERCIAL RANGES V <sub>CC</sub> = 5V ± 5%, T <sub>A</sub> = 0°C to 70°C
Ceramic DIP	SCN2671AC1140
Plastic DIP	SCN2671AC1N40

# PROGRAMMABLE KEYBOARD AND COMM CONTROLLER (PKCC)    SCN2671

## PIN DESIGNATION

MNEMONIC	PIN NO.	TYPE	NAME AND FUNCTION
D0-D7	16-19, 23-26	I/O	<b>Data Bus:</b> 8-bit three-state bidirectional data bus. All data, command and status transfers are made using this bus. D0 is the least significant bit; D7 is the most significant bit.
A0-A2	31-33	I	<b>Address Lines:</b> Used to select internal PKCC registers or commands.
$\overline{RD}$	29	I	<b>Read Strobe:</b> When low, gates the selected PKCC register onto the data bus if $\overline{CE}$ is also low.
$\overline{WR}$	28	I	<b>Write Strobe:</b> When low, gates the contents of the data bus into the selected PKCC register if $\overline{CE}$ is also low.
$\overline{CE}$	30	I	<b>Chip Enable:</b> When high, places the D0-D7 output drivers in a three-state condition. If $\overline{CE}$ is low, data transfers are enabled in conjunction with the $\overline{RD}$ and $\overline{WR}$ inputs.
$\overline{INTR}$	22	O	<b>Interrupt Request:</b> Several conditions may be programmed to request an interrupt to the CPU. It is an active low open-drain output. This pin will be inactive after power on reset or a master reset command.
$\overline{INTA}$	27	I	<b>Interrupt Acknowledge:</b> Used to indicate that an interrupt request has been accepted by the CPU. When $\overline{INTA}$ goes low, the PKCC outputs an 8-bit address vector on D0-D7 corresponding to the highest priority interrupt currently active.
$\overline{XINTR}$	21	I	<b>External Interrupt:</b> An active low external interrupt input to the PKCC interrupt priority resolver.
TxC	34	I/O	<b>Transmitter Clock:</b> The function of this pin depends on bit 7 of the baud rate control register (BRR7). If external transmitter clock is selected (BRR7 = 0), it is an input for the transmitter clock. If internal transmitter clock is selected (BRR7 = 1), this pin is an output which is a multiple of the actual baud rate (1X, 16X) as selected by BRR5. The data is transmitted on the falling edge of TxC. It is an input after power on and after master reset or communications reset commands.
RxC	35	I/O	<b>Receiver Clock:</b> The function of this pin depends on BRR6. If external receiver clock is selected (BRR6 = 0), it is an input for the receiver clock. If internal receiver clock is selected (BRR6 = 1), this pin is an output which is a multiple of the actual baud rate (1X, 16X) as selected by BRR4. The received data is sampled on the rising edge of RxC. It is an input after power on and after master reset or communications reset commands.
TxD	38	O	<b>Transmitter Data:</b> This output is the transmitted serial data; the least significant bit is transmitted first. This pin is high after power on reset or a reset command that affects the transmitter.
RxD	39	I	<b>Receiver Data:</b> This input is the serial data input to the receiver. The least significant bit is received first.
XTAL1 XTAL2/BRCLK	36,37	I	<b>Connections for Crystal:</b> Provides an on-chip clock generator for the internal baud rate generator and the keyboard interface logic. If an external clock is provided, use XTAL2 as the clock input. See figures 20 and 21.  All timing parameters such as keyboard scan time, tone frequency, and baud rate assume a clock input at the specified BRG input frequency. If this frequency is different, the timing parameters will vary proportionately.
KRO-KR2	10-8	O	<b>Keyboard Row Scan:</b> Decoded externally; selects one of eight rows.
KCO-KC3	7-4	O	<b>Keyboard Column Scan:</b> Decoded externally; selects one of 16 columns.
KRET	15	I	<b>Key Return:</b> An active high level indicates that the key being scanned is closed.
$\overline{SHIFT}$	12	I	<b>SHIFT Key:</b> Active low input from the SHIFT key. The combination of $\overline{SHIFT}$ and $\overline{CONTROL}$ inputs select one of four possible codes from the internal key encoding ROM.
$\overline{CONTROL}$	13	I	<b>CONTROL Key:</b> Active low input from the CONTROL key. The combination of $\overline{SHIFT}$ and $\overline{CONTROL}$ inputs select one of four possible codes from the internal key encoding ROM.

# PROGRAMMABLE KEYBOARD AND COMM CONTROLLER (PKCC) SCN2671

## PIN DESIGNATION (Cont.)

REPEAT	11	I	<b>REPEAT Key:</b> Active low input from the REPEAT key. Causes the key depression currently active to be repeated at a rate of approximately 15 times per second.
KCLK	3	O	<b>Keyboard Clock:</b> High frequency (approximately 400 kHz) output used to scan capacitive keyboards.
KDRES	2	O	<b>Key Detect Reset:</b> Resets the analog detector before scanning a key. Used for capacitive keyboards.
HYS	1	O	<b>Hysteresis Output:</b> Sent to the analog detector for capacitive keyboard applications. A low indicates the key currently being scanned has been recognized on previous scan cycles.
TONE	14	O	<b>Square Wave Output:</b> Used for tone generation.
VCC	40	I	+5V power supply.
VSS	20	I	Ground.

### Receiver

The receiver accepts serial data on the RxD pin, converts this serial input to parallel format, checks for break conditions, framing and parity errors, and loads an "assembled" character in the receive holding register for access by the CPU.

### Transmitter

The transmitter accepts parallel data loaded by the CPU into the transmit holding register and converts it to a serial bit stream framed by the start bit, calculated parity bit (if specified), and stop bit(s). The composite serial stream of data is transmitted on the TxD output pin.

### Keyboard Encoder

The keyboard encoder provides encoded

scanning signals for a matrix keyboard. Key depressions are detected on the KRET input. The debounced and verified key codes (or matrix addresses) are loaded into the key holding register for access by the CPU. Figures 1 and 2 illustrate the PKCC interface to contact and capacitive keyboards, respectively.

### Interrupt Control

The interrupt controller unit contains a software programmable interrupt mask register which selectively enables status conditions from the keyboard encoder and communication controller to generate interrupts. The interrupts are priority encoded and individually generate an eight bit vector which is output on the data bus in response to a CPU interrupt acknowledge on the INTA input pin.

### OPERATION

#### Keyboard Encoder

The keyboard is continuously scanned by KC0-KC3 and KR0-KR2 which are decoded externally to handle 128 possible keys (see figures 1 and 2). KC0-KC3 select one of 16 columns and KR0-KR2 multiplex the eight row return lines into the KRET pin. Debouncing is accomplished by remembering a 1 state at the KRET pin when a key is being addressed and verifying it one scan later. Once the key is verified, a key code is loaded into the keyboard data register (KDR). If the keyboard holding register (KHR) is empty, the contents of the KDR will be transferred to the KHR immediately; if the KHR is full (i.e., the CPU has not read the previous key code), the transfer will be held off until the KHR is read. The data transfer to the KHR causes keyboard data ready (KRDY) to be set in the keyboard status register.

For capacitive keyboards, the high frequency output KCLK can be used to gate the column scan to the keyboard (see figure 2). The key detector reset (KDRES) output resets the analog detector prior to scanning each key location. The output from the analog multiplexer is sensed and then latched in the analog detector. The HYS output controls the sense level. A 0 will lower the sense level causing hysteresis, and a 1 will raise the sense level with no hysteresis.

The REPEAT input enables the keyboard logic to recognize any key repeatedly, 15 times per second. Additionally, certain keys can be programmed to repeat automatically if depressed for more than one-half second.

A square wave is output on the TONE pin when the CPU issues a ring tone command to the PKCC.

Table 1 2671 REGISTER ADDRESSING

CE	A2	A1	A0	RD/WR	FUNCTION
1	X	X	X	X	Three-state data bus
0	0	0	0	WR	Reset command (see table 6)
0	0	0	0	RD	Read interrupt status register (ISR)
0	0	0	1	RD, WR	Read/write communications mode register (CMR)
0	0	1	0	WR	Write transmit holding register (TxHR)
0	0	1	0	RD	Read receiver holding register (RxHR)
0	0	1	1	WR	Write baud rate mode register (BRR)
0	0	1	1	RD	Read communications status register (CSR)
0	1	0	0	RD, WR	Read/write interrupt mask register (IMR)
0	1	0	1	RD, WR	Read/write keyboard mode register (KMR)
0	1	1	0	RD	Read keyboard holding register (KHR)
0	1	1	1	RD	Read keyboard status register (KSR)
0	1	1	1	WR	Miscellaneous commands (see description)

NOTE  
X = don't care.

# PROGRAMMABLE KEYBOARD AND COMM CONTROLLER (PKCC) SCN2671

## BLOCK DIAGRAM

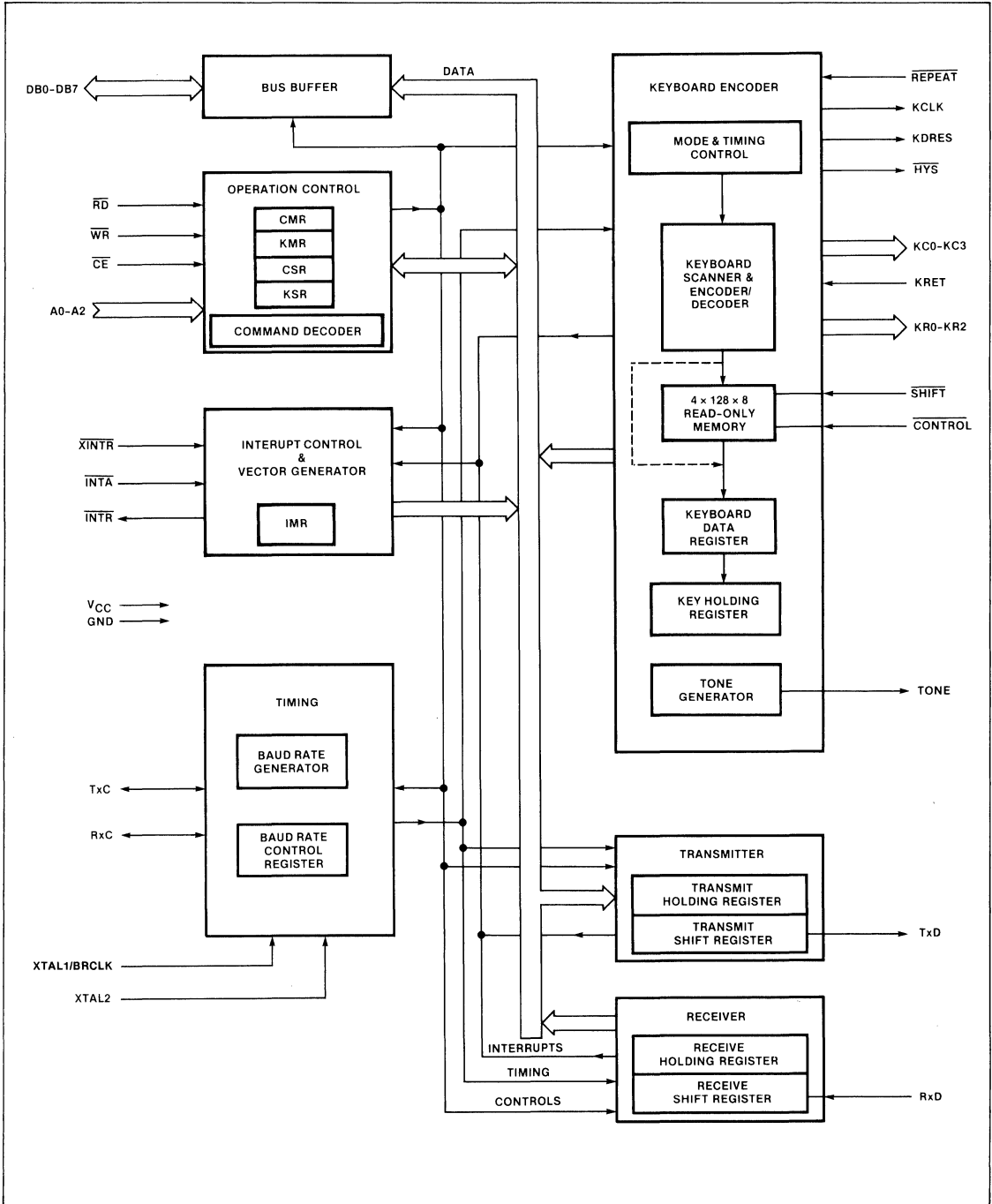

2

**PROGRAMMABLE KEYBOARD AND COMM CONTROLLER (PKCC) SCN2671**

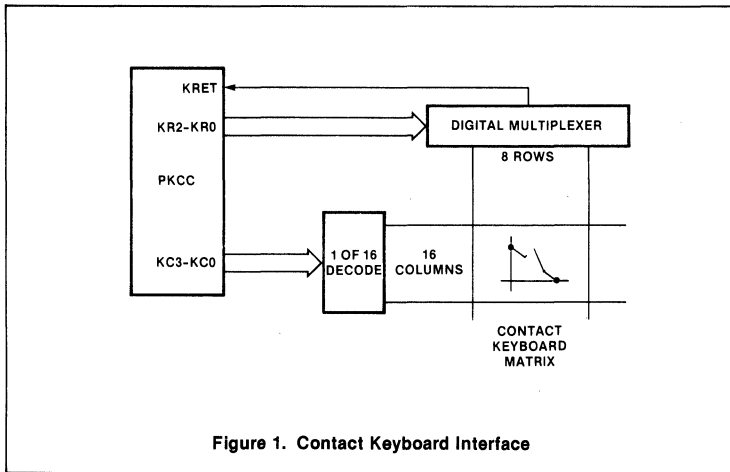

Figure 1. Contact Keyboard Interface

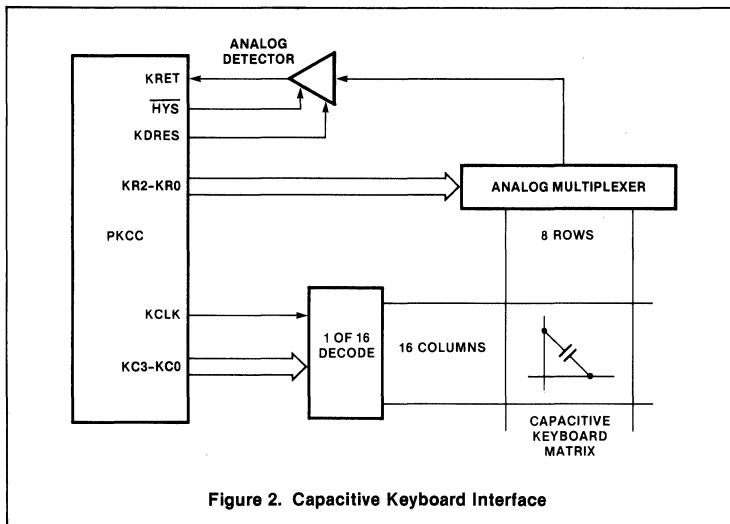

Figure 2. Capacitive Keyboard Interface

the code in the KDR is transferred to the KHR and the KRDY status bit is set (KSRO).

**N-Key Rollover With Latched Keys:** This mode is the same as regular N-key rollover, except that the keys which are assigned to row 0 of the keyboard matrix (KR2-KR0 = 000) produce a code both when depressed and when released. The codes are independent of the states of the inputs at SHIFT and CONTROL. If one or more of the latched keys are depressed when the keyboard is enabled (after a keyboard reset), the corresponding codes will be sent out as the keys are scanned and debounced. Note that simultaneous latched keys will not set KERR (KSR1) and that latched keys will not be auto-repeat and will not be affected by the REPEAT input.

**Two-Key Rollover:** The first key code is loaded into the KDR immediately and the second code is loaded only after the first key is released. Simultaneous keys will set KERR (KSR1). If three or more keys remain closed at any given time, the KERR bit will also be set. All keys must then be released before the next KRET will be processed.

**Two-Key Inhibit:** All keys must be released between keystrokes; otherwise, KERR (KSR1) will be set.

Bit KMR4 specifies the key encoding mode. Each key is assigned four 8-bit codes, corresponding to the states of the SHIFT and CONTROL inputs. If the encoded mode is programmed, the row/column address of the detected key is used to load one of the four key codes into the KDR. See table 2 for key code assignments. If the non-encoded mode is programmed, the row/column address is loaded directly into the KDR with the following format:

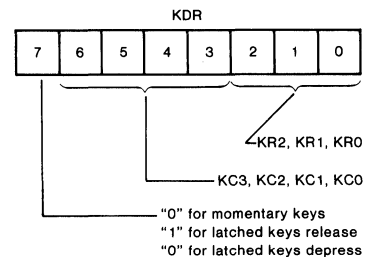

**Keyboard Mode Register**

Operating modes are selected by programming the keyboard mode register (KMR), whose format is illustrated in figure 3.

Bit KMR7 is used for testing the device. For normal operation, this bit should always be written to a 0.

Bits KMR6-KMR5 select the rollover modes for keyboard processing:

**N-key Rollover:** In this mode, the code corresponding to each key depression is loaded into the KDR as soon as that key is debounced, independent of the release of other keys. Two or more closures occurring within one scan cycle are considered to be simultaneous, which will set keyboard error in the keyboard status register (KSR1). As soon as the keyboard holding register is empty,

# PROGRAMMABLE KEYBOARD AND COMM CONTROLLER (PKCC) SCN2671

Table 2 STANDARD KEY CODES (HEX)

COLUMN (KC3-KC0)	ROW (KR2-KR0)							
	0	1	2	3	4	5	6	7
0	E0 F0 E0 F0	C0 D0 C0 D0	1B ESC 1B ESC 1B ESC 1B ESC	09 HT 09 HT 09 HT 09 HT	0F US 1F US 1F US 1F US	1A SUB 1A SUB 5A Z 7A z	30 0 30 0 30 0 30 0	2B + 3B : 2B + 3B :
1	E1 F1 E1 F1	C1 D1 C1 D1	21 ! 31 ! 21 ! 31 !	11 DC1 11 DC1 51 Q 71 q	01 SOH 01 SOH 41 A 61 a	18 CAN 18 CAN 58 X 78 x	3D = 2D - 3D = 2D -	2A * 3A : 2A * 3A :
2	E2 F2 E2 F2	C2 D2 C2 D2	22 " 32 2 22 " 32 2	17 ETB 17 ETB 57 W 77 w	13 DC3 13 DC3 53 S 73 s	03 ETX 03 ETX 43 C 63 c	1E RS 1E RS 7E ~ 5E ↑	1F US 1F US 7F * DEL 5F -
3	E3 F3 E3 F3	C3 D3 C3 D3	23 # 33 3 23 # 33 3	05 ENQ 05 ENQ 45 E 65 e	04 EOT 04 EOT 44 D 64 d	16 SYN 16 SYN 56 V 76 v	1C FS 1C FS 7C ! 5C \	1B ESC 1B ESC 7B { 5B [
4	E4 F4 E4 F4	C4 D4 C4 D4	24 \$ 34 4 24 \$ 34 4	12 DC2 12 DC2 52 R 72 r	06 ACK 06 ACK 46 F 66 f	02 STX 02 STX 42 B 62 b	08 BS 08 BS 08 * BS 08 * BS	1D GS 1D GS 7D } 5D ]
5	E5 F5 E5 F5	C5 D5 C5 D5	25 % 35 5 25 % 35 5	14 DC4 14 DC4 54 T 74 t	07 BEL 07 BEL 47 G 67 g	0E SO 0E SO 4E N 6E n	10 DLE 10 DLE 50 P 70 p	08 BS 08 BS 08 BS 08 * BS
6	E6 F6 E6 F6	C6 D6 C6 D6	26 & 36 6 26 & 36 6	19 EM 19 EM 59 Y 79 y	08 BS 08 BS 48 H 68 h	0D CR 0D CR 4D M 6D m	00 NUL 00 NUL 60 @ 40 @	09 HT 09 HT 09 * HT 09 * HT
7	E7 F7 E7 F7	C7 D7 C7 D7	27 ' 37 7 27 ' 37 7	15 NAK 15 NAK 55 U 75 u	0A LF 0A LF 4A J 6A j	3C < 2C < 3C < 2C <	7F DEL 2C DEL 7F DEL 7F DEL	20 SP 20 SP 20 * SP 20 * SP
8	E8 F8 E8 F8	C8 D8 C8 D8	28 ( 38 8 28 ( 38 8	09 HT 09 HT 49 I 69 i	0B VT 0B VT 4B K 6B k	3E > 2E > 3E > 2E >	0A LF 0A LF 0A LF 0A LF	0B VT 0B VT 0B * VT 0B * VT
9	E9 F9 E9 F9	C9 D9 C9 D9	29 ) 39 9 29 ) 39 9	0F SI 0F SI 4F O 6F o	0C FF 0C FF 4C L 6C l	3F ? 2F / 3F ? 2F /	0D CR 0D CR 0D CR 0D CR	0A LF 0A LF 0A * LF 0A * LF
A	EA FA EA FA	CA DA CA DA	37 7 37 7 37 7 37 7	34 4 34 4 34 4 34 4	31 1 31 1 31 1 31 1	30 0 30 0 30 0 30 0	A0 B0 A0 B0	A6 B6 A6 B6
B	EB FB EB FB	CB DB CB DB	38 8 38 8 38 8 38 8	35 5 35 5 35 5 35 5	32 2 32 2 32 2 32 2	2E . 2E . 2E . 2E .	A1 B1 A1 B1	A7 B7 A7 B7
C	EC FC EC FC	CC DC CC DC	39 9 39 9 39 9 39 9	36 6 36 6 36 6 36 6	33 3 33 3 33 3 33 3	BF AF 9F 8F	A2 B2 A2 B2	A8 B8 A8 B8
D	ED FD ED FD	CD DD CD DD	90 90 90 90	93 93 93 93	82 82 82 82	95 95 95 95	A3 B3 A3 B3	A9 B9 A9 B9
E	EE FE EE FE	CE DE CE DE	91 91 91 91	80 80 80 80	84 84 84 84	81 81 81 81	A4 B4 A4 B4	AA BA AA BA
F	EF FF EF FF	CF DF CF DF	92 92 92 92	94 94 94 94	83 83 83 83	96 96 96 96	A5 B5 A5 B5	AB BB AB BB

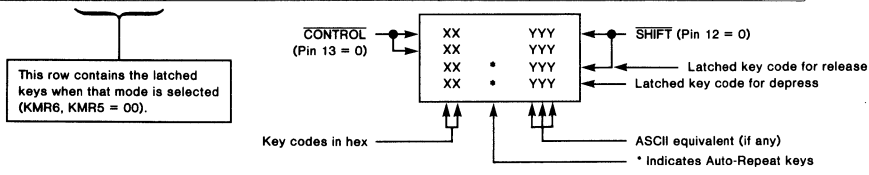

This row contains the latched keys when that mode is selected (KMR6, KMR5 = 00).

**PROGRAMMABLE KEYBOARD AND COMM CONTROLLER (PKCC) SCN2671**

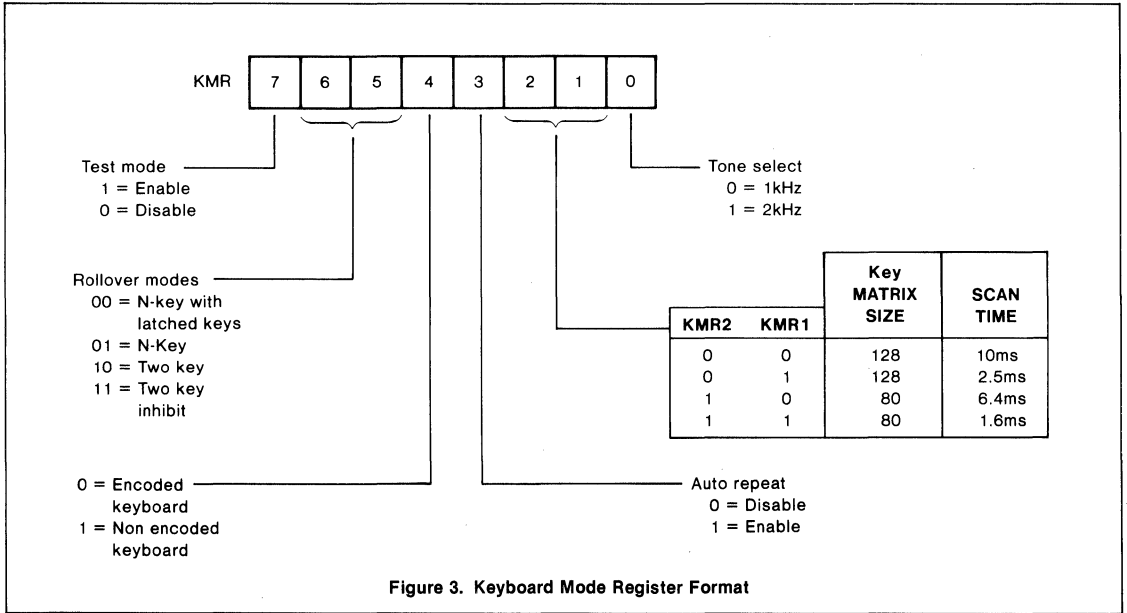

Figure 3. Keyboard Mode Register Format

Bit KMR3 enables the auto-repeat mode. In this mode, if a key that is programmed for auto-repeat is depressed for longer than one-half second, the key code will be loaded into the KDR approximately 15 times per second until that key is released. Only the non-control key codes will auto-repeat, i.e. CONTROL = 1. Table 2 specifies the auto-repeat keys.

KMR2 and KMR1 select the key matrix size and debounce time (scan rate). The keyboard row outputs (KR2, KR1, KR0) always scan from 0 to 7. The column outputs (KC3, KC2, KC1, KC0) scan from 0 to 15 for a 128 key matrix and from 0 to 9 for an 80 key matrix.

KMR0 selects between a 1kHz and 2kHz frequency to be output on the TONE pin in response to a ring tone command.

**Keyboard Status Register**

The keyboard status register (KSR) provides operational feedback to the CPU. Its format is illustrated in figure 4.

KSR7, 6 and 4 reflect the state of the inputs at the corresponding pins. CONTROL and SHIFT are latched at the time the key is accepted. As the verified codes are loaded into the KDR, the corresponding states of CONTROL and SHIFT are loaded into the KSR. REPEAT is updated on every matrix

sample. The status bits are the complements of the input levels.

KSR5 reflects the state of the internal shift lock flag which is controlled by the set/reset shift lock commands.

KSR3 indicates that the keyboard controller is enabled. It is controlled by the set/clear keyboard enable command.

Keyboard overrun (KSR2) is set when both the KHR and KDR are full and a third key is validated. The original content of the KHR is preserved and the content of the KDR is overwritten with the new key code. This bit can be specified (by IMR1) to generate an

interrupt and is cleared by the reset command with D2 = 1.

Keyboard error (KSR1) is set when the operator depresses more keys than are allowed in the selected rollover mode, or when keys are depressed simultaneously (within one scan cycle). This bit can be specified (by IMR3) to generate an interrupt and is cleared by the reset command with D1 = 1.

Keyboard data ready (KSR0) is set when the key code or address is transferred from the KDR to the KHR. This bit can be specified (by IMR2) to generate an interrupt. It is cleared when the CPU reads the KHR.

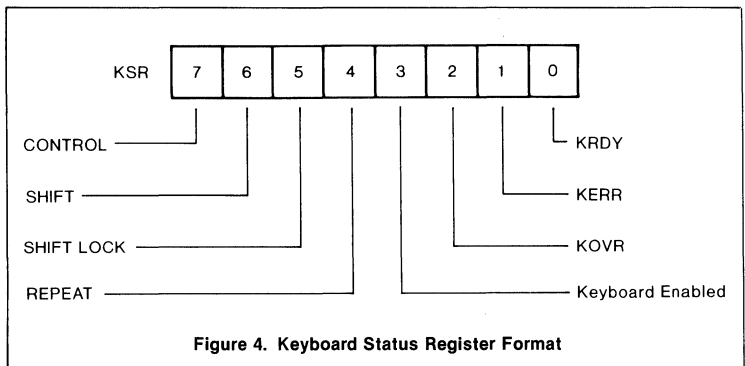

Figure 4. Keyboard Status Register Format

# PROGRAMMABLE KEYBOARD AND COMM CONTROLLER (PKCC) SCN2671

## Communications Controller

The communications controller section of the PKCC comprises a full duplex asynchronous receiver/transmitter (UART) with a baud rate generator. Registers associated with these elements are the communications mode register (CMR), the baud rate control register (BRR), and the communications status register (CSR).

## Receiver

The receiver accepts serial data on the RxD pin, converts the serial input to parallel format, checks for start bit, stop bit, parity bit (if any), or break condition, and presents the assembled character to the CPU. The receiver looks for a high to low (mark to space) transition of the start bit on the RxD input pin. If a transition is detected, the state of the RxD pin is sampled again after a delay of one half of the bit time. If RxD is then high, the start bit is invalid and the search for a valid start bit begins again. If RxD is still low, a valid start bit is assumed and the receiver continues to sample the input at one bit time intervals at the theoretical center of the bit, until the proper number of data bits and the parity bit (if any) have been assembled, and one stop bit has been detected. The least significant bit is received first. The data is then transferred to the receive holding register (RxHR) and the RxRDY bit in the CSR is set to a 1. If the character length is less than eight bits, the most significant unused bits in the RxHR are set to zero.

After the stop bit is detected, the receiver will immediately look for the next start bit. However, if a non-zero character was received without a stop bit (i.e. framing error) and RxD remains low for one half of the bit period after the stop bit was sampled, then the space is interpreted as a start bit.

The parity error, framing error and overrun error (if any) are strobed into the CSR at the received character boundary. If a break condition is detected (RxD is low for the entire character including the stop bit) only one character consisting of all zeros will be transferred to the RxHR and the received break bit in the CSR is set to 1 (RxRDY is not set when a break is received). The RxD input must return to a high condition for one bit time before a search for the next start bit begins.

## Transmitter

The transmitter accepts parallel data from the CPU and converts it to a serial bit stream on the TxD output pin. It automatically sends a start bit followed by the data bits, an optional parity bit, and the programmed number of stop bits. The least significant bit is

sent first. Following the transmission of the stop bits, if a new character is not available in the transmit holding register (TxHR), the TxD output remains high and the TxEMT bit in the CSR will be set to 1. Transmission resumes and the TxEMT bit is cleared when the CPU loads a new character into the TxHR. The transmitter can be forced to send a continuous low condition by a transmit break command.

If the transmitter is disabled, it continues operating until the character currently being transmitted is completely sent out.

## Communication Mode Register

Figure 5 illustrates the bit format of the CMR, which controls the operational mode of the communications controller and the character parameters.

Bits CMR1-CMR0 select a character length of 5, 6, 7, or 8 bits. The character length does not include the parity, start, or stop bits.

CMR2 selects the transmitted character framing as one or two stop bits. The receiver always checks for one stop bit.

The parity format is selected by bits CMR4 and CMR3. If parity or force parity is selected, a parity bit is added to the transmitted character and the receiver performs a parity check on incoming data. CMR5 selects odd or even parity and determines the polarity of the parity bit in the force parity mode.

The bits in the mode register affecting character assembly and disassembly (CMR5-CMR0) can be changed dynamically and affect the characters currently being assembled in RxSR and transmitted by TxSR. To

affect assembly of a received character, the CMR must be updated within  $n - 1$  bit times of the receipt of that character's start bit. To affect a transmitted character, the CMR must be updated within  $n - 1$  bit times of transmitting that character's start bit. ( $n =$  the smaller of the new and old character lengths).

The UART can operate in one of four modes, as illustrated in figure 6. The operating modes are selected by bits CMR7 and CMR6, which should only be changed when both the transmitter and receiver are disabled. CMR7-CMR6 = 00 is the normal mode, with the transmitter and receiver operating independently. CMR7-CMR6 = 01 places the UART in the automatic echo mode, which automatically retransmits the received data. The following conditions are true while in automatic echo mode:

1. Data assembled by the receiver is automatically placed in the transmit holding register and retransmitted on the TxD output.
2. The receive clock is used for the transmitter.
3. The receiver must be enabled, but the transmitter need not be enabled.
4. Status bit TxRDY is not set. TxEMT operates normally.
5. The received parity is checked, but is not regenerated for transmission, i.e., transmitted parity bit is as received.
6. Only the first character of a break condition is echoed; the TxD output will go high until the next received character is assembled.
7. CPU to receiver communication continues normally, but the CPU to transmitter link is disabled.

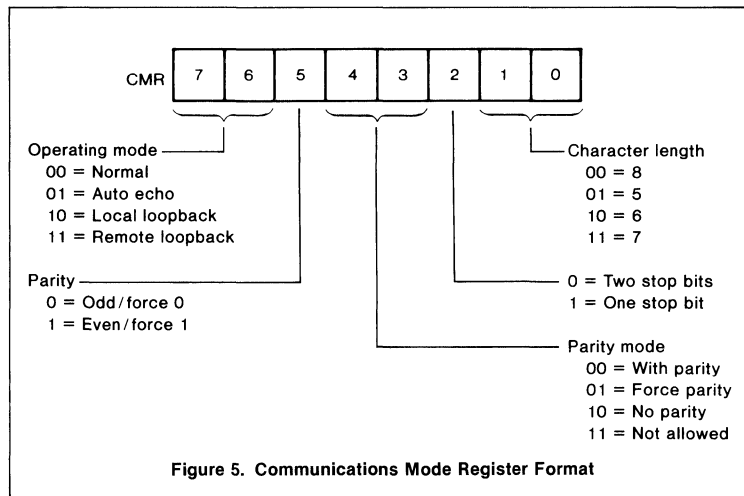
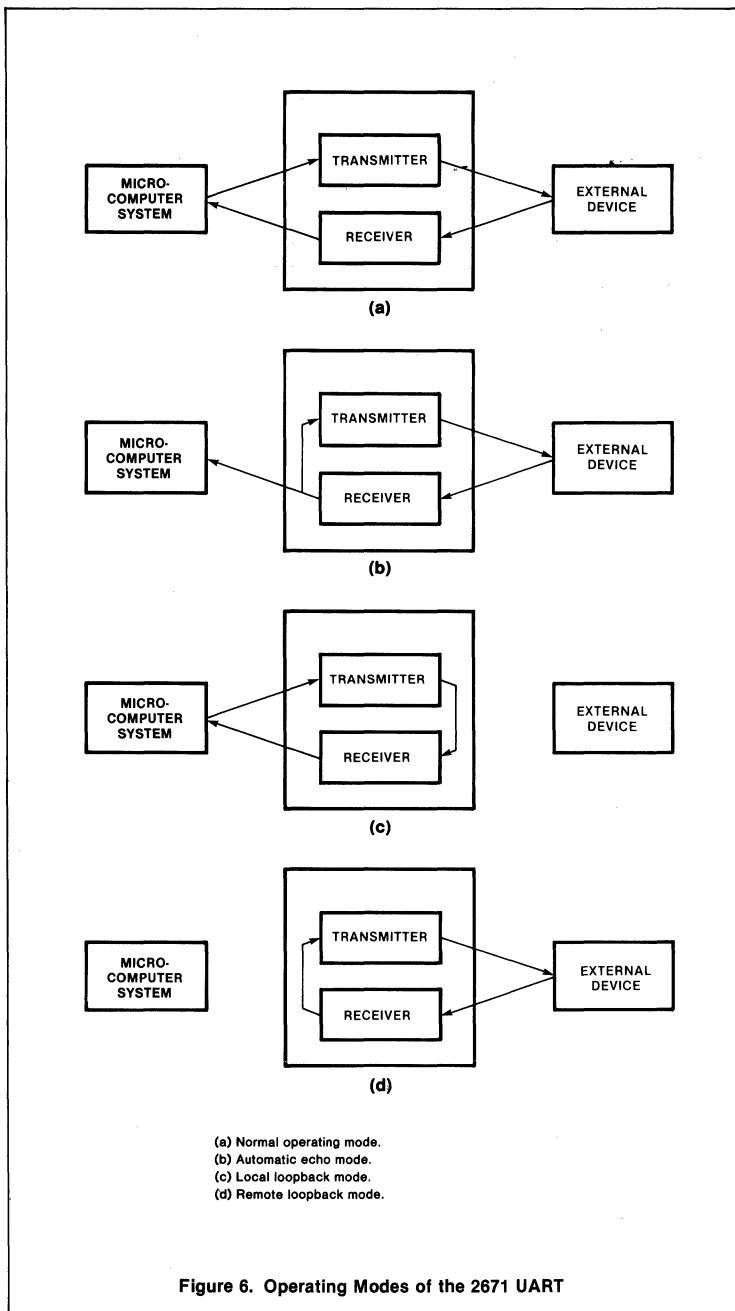

Figure 5. Communications Mode Register Format

# PROGRAMMABLE KEYBOARD AND COMM CONTROLLER (PKCC) SCN2671



Two diagnostic modes can also be configured. In local loopback mode (CMR7-CMR6 = 10):

1. The transmitter output is internally connected to the receiver input.
2. The transmit clock is used for the receiver.
3. The TxD output is held high.
4. The RxD input is ignored.
5. The transmitter must be enabled, but the receiver need not be enabled.
6. CPU to transmitter and receiver communications continue normally.

The second diagnostic mode is the remote loopback mode (CMR7-CMR6 = 11). In this mode:

1. Data assembled by the receiver is automatically placed in the transmit holding register and retransmitted on the TxD output.
2. The receive clock is used for the transmitter.
3. No data is sent to the local CPU, but the error status conditions (parity and framing) are set if required.
4. The received parity is checked, but is not regenerated for transmission, i.e., transmitted parity bit is as received.
5. The receiver must be enabled, but the transmitter need not be enabled.

### Baud Rate Control Register

The baud rate control register (BRR) controls the frequency generated by the baud rate generator (BRG) and the clock source used by the receiver and transmitter. Its format is illustrated in figure 7.

BRR3-BRR0 select one of sixteen frequencies to be generated by the BRG. See table 3.

BRR7 and BRR6 select the source of the transmit and receive clocks. If external clocks are chosen, (BRR7 = 0 or BRR6 = 0), then the clock rate factor is determined by BRR5 and BRR4. The external clock input(s) should be the desired baud rate multiplied by the clock rate factor.

If internal clock(s) are specified, (BRR7 = 1 or BRR6 = 1), the clock is supplied by the internal baud rate generator at the selected baud rate. The clock rate factor for internally generated clocks is always 16. Pins 35 and 34 become outputs for transmit or receive clocks, respectively. See table 4 for the description and selection of these outputs.

**PROGRAMMABLE KEYBOARD AND COMM CONTROLLER (PKCC) SCN2671**

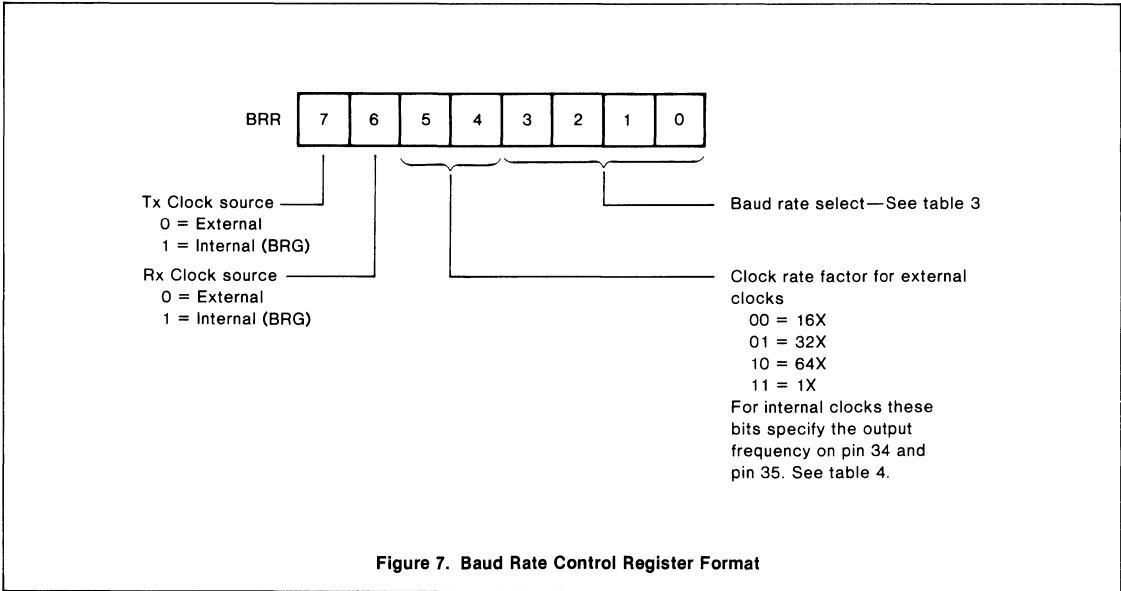

**Table 3 BAUD RATE GENERATOR CHARACTERISTICS (BRCLK = 4.9152MHz)**

BRR3-0	BAUD RATE	ACTUAL FREQUENCY 16X CLOCK	PERCENT ERROR	DIVISOR
0000	50	0.8 kHz	—	6144
0001	110	1.7598	-0.01	2793
0010	134.5	2.152	—	2284
0011	150	2.4	—	2048
0100	200	3.2	—	1536
0101	300	4.8	—	1024
0110	600	9.6	—	512
0111	1050	16.8329	+0.20	292
1000	1200	19.2	—	256
1001	1800	28.7438	-0.20	171
1010	2000	31.9168	-0.26	154
1011	2400	38.4	—	128
1100	4800	76.8	—	64
1101	9600	153.6	—	32
1110	19200	307.2	—	16
1111	38400	614.4	—	8

# PROGRAMMABLE KEYBOARD AND COMM CONTROLLER (PKCC) SCN2671

**Table 4 BAUD RATE CONTROL REGISTER**

BRR7-BRR4	CLOCK SOURCE		PIN FUNCTIONS		BRR3-BRR0 BAUD RATE SELECTION
	TxC	RxC	PIN 34	PIN 35	
00**	E	E	TxC	RxC	The baud rates are listed in table 3.
01**	E	I	TxC	1X	
10**	I	E	16X	RxC	
1100	I	I	1X	1X	
1101	I	I	1X	16X	
1110	I	I	16X	1X	
1111	I	I	16X	16X	

**NOTES**

- \*\* = Clock rate factor for external clocks: 00 = 16X  
01 = 32X  
10 = 64X  
11 = 1X
- E = External clock.
- I = Internal clock (BRG).
- 1X and 16X are clock outputs at 1 or 16 times the actual baud rate. For receive, the 1X output is the actual data sample clock.
- BRR7-BRR6 = 01 or 10 not permitted in automatic echo or remote loopback modes unless BRR5-BRR4 = 00.

## Communications Status Register

Figure 8 illustrates the bit format of the communications status register (CSR), which provides UART status to the CPU.

Receiver ready (CSR0) indicates that a received character is assembled and transferred to the RxHR and is ready to be read by the CPU. This bit can be specified (by IMR0) to generate an interrupt and is reset by reading the RxHR.

Transmitter ready (CSR1) indicates that the TxHR is empty and ready to be loaded with a character. This bit will be cleared when the TxHR is loaded and has not yet transferred the character to the transmit shift register (TxSR). TxRDY is reset when the transmitter is disabled. It will be set when the transmitter is enabled, provided that no data was loaded into the TxHR during the time the transmitter was disabled. This bit can be specified (by IMR7) to generate an interrupt.

Transmitter empty (CSR2) indicates that the transmitter has underrun, i.e., both the TxHR and TxSR are empty. This bit can only be set after transmission of at least one character, and is cleared when the TxHR is loaded by the CPU. TxEMT is reset when the transmitter is disabled. This bit can be specified (by IMR6) to generate an interrupt.

CSR3 will be set when the PKCC receives a command to transmit a break. This bit will be cleared after the break is completed.

Received break (CSR4) indicates that an all zero character of the programmed length has been received without a stop bit. Breaks originating in the middle of a received character can be detected. This bit is cleared

when RxD returns to a high state for at least one bit time.

Receiver overrun (CSR5) indicates that the previous character in the RxHR has not been read by the CPU and that a new character has been loaded into the RxHR. This bit is cleared by a reset command with D3 = 1.

Framing error (CSR6) indicates that the stop bit has not been detected. The stop bit check is made in the middle of the first stop bit position. This bit is cleared by a reset command with D3 = 1.

Parity error (CSR7) indicates that a character was received with incorrect parity when 'with parity' or 'force parity' is enabled. This bit is cleared by a reset command with D3 = 1.

## Interrupt Controller

The 2671 contains a maskable interrupt sta-

tus register (ISR) which can be enabled to generate an active low interrupt request on the INTR output. The eight interrupt conditions in the ISR are individually enabled by writing a 1 into the corresponding bit of the interrupt mask register (IMR).

Each of the interrupt conditions is assigned a priority and a vector. When an enabled ISR bit is set, the 2671 asserts the INTR output. If the CPU activates the INTA input, the 2671 responds by placing the corresponding 8-bit vector on the data bus (D7-D0). If multiple interrupts are pending, the vector corresponds to the condition with the highest priority. The interrupt will persist until all pending interrupt conditions are cleared.

The ISR can also be polled by reading at address A2-A0 = 000. All pending interrupt conditions which are enabled by the IMR will be read independent of priority.

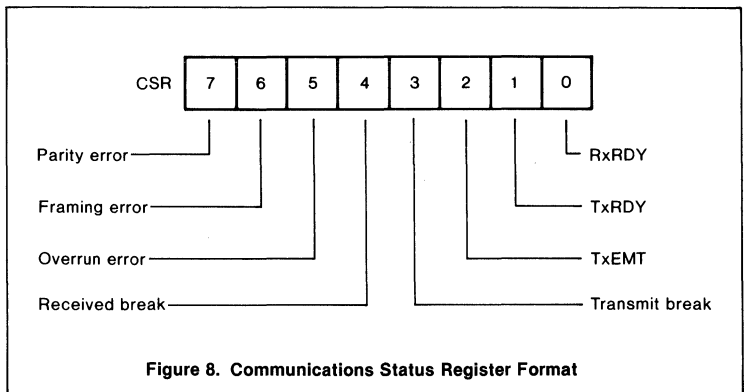

**Figure 8. Communications Status Register Format**

# PROGRAMMABLE KEYBOARD AND COMM CONTROLLER (PKCC) SCN2671

The bit assignments of the ISR and IMR and corresponding vectors and priorities are listed in table 5.

### COMMANDS

In addition to the control exercised by programming of the PKCC control registers, several functions can be performed by executing command operations. There are two classes of commands which are initiated by writing to the 2671 at address A2-A0 = 000 (reset command) and address A2-A0 = 111 (miscellaneous commands). Individual commands are specified by the bit pattern on the data bus (D7-D0).

### Reset Commands

The reset command bit format is illustrated in figure 9 and the detail command descriptions are given in table 6.

A reset command with D7-D0 = 111XXXX1 is a master reset for the 2671. This command must be given following a power on condition to release the internal power on reset latch which deactivates the 2671 on power up.

### Miscellaneous Commands

The miscellaneous command format is illustrated in figure 10.

The transmit break commands force a break (steady low output) on the TxD pin immediately or after the character in the TxSR (if any) is transmitted. A timed break lasts for approximately 200ms, and a character break lasts for one character time including parity and stop bit time. In either case, TxRDY (CSR1) will be set at the beginning of

the break which can be extended indefinitely (by 200ms or one character time increments) by reasserting the command in response to TxRDY. Note that these commands reset TxRDY. When a transmit break command is asserted, CSR3 will be set. This bit will be cleared after the break is completed.

The ring tone commands cause the tone generator to output a square wave on the TONE output. The tone durations are specified by the commands:

- Ring tone short = 25ms
- Ring tone long = 100ms

The tone frequency is either 1kHz or 2kHz, as specified by KMR0.

**TABLE 5 INTERRUPT MASK REGISTER (IMR) AND INTERRUPT STATUS REGISTER (ISR)**

BIT IN IMR /ISR	INTERRUPT CONDITION	PRIORITY	VECTOR ON D7-D0		CONDITION RESET BY:
			BINARY	HEX	
IMR0 /ISR0	RxRDY	1	11001111	CF	Read RxHR
IMR1 /ISR1	KOVR	2	11010111	D7	Reset CMD (D2 = 1)
IMR2 /ISR2	KRDY	3	11011111	DF	Read KHR
IMR3 /ISR3	KERR	4	11100111	E7	Reset CMD (D1 = 1)
IMR4 /ISR4	XINT <sup>1</sup>	5	11101111	EF	External
IMR5 /ISR5	ΔBREAK <sup>2</sup>	6	11110111	F7	Reset CMD (D4 = 1)
IMR6 /ISR6	TxE <sup>M</sup>	7	11000111	C7	Load TxHR
IMR7 /ISR7	TxRDY	8	11000111	C7	Load TxHR

**NOTES:**

1. XINT is an Input from an external interrupt source, active low (pin 21).
2. ΔBREAK refers to the change of a received break condition.

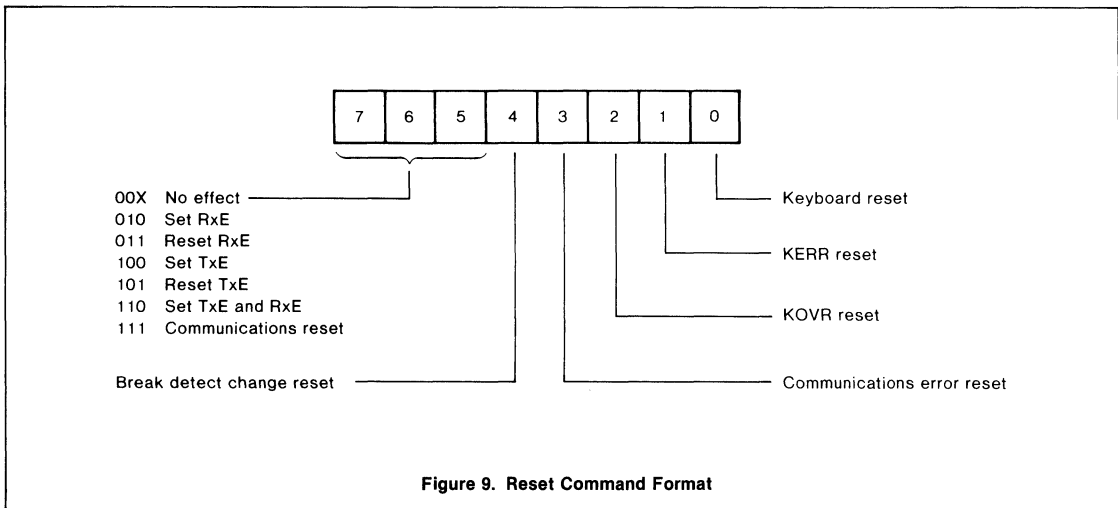

**Figure 9. Reset Command Format**



# PROGRAMMABLE KEYBOARD AND COMM CONTROLLER (PKCC) SCN2671

**Table 6 RESET COMMAND DESCRIPTION**

COMMAND	RESETS	COMMENTS
Keyboard reset	KMR7-KMR0 KSR5, KSR3-KSR0 IMR3-IMR1	The keyboard controller is reset, ignoring the input at KRET.
KERR reset	KSR1	Keyboard error status bit reset.
KOVR reset	KSR2	Keyboard overrun status bit reset.
Communications error reset	CSR7-CSR5	Resets the receiver overrun, parity, and framing error status bits.
Break detect change reset	ISR5	Resets the break detect change bit in the interrupt status register.
Set RxE	See note.	Enables receiver operation.
Reset RxE	CSR7-CSR4, CSR0 See note.	Disables the receiver.
Set TxE	See note.	Enables transmitter operation.
Reset TxE	CSR3-CSR1 See note.	Disables the transmitter. Sets the TxD output to a 1 after transmitting the character in TxSR.
Communications reset	CMR, CSR, BRR, TxE, RxE, IMR7-IMR5, IMR0	Resets the communication controller. The RxD input is ignored and the TxD output is set to a 1.
Master reset	CMR, CSR, BRR, TxE, RxE, KMR, KSR5, KSR3-KSR0, IMR7-IMR0. Releases the internally latched power on reset.	Resets the keyboard and communication controllers. Inputs at KRET and RxD are ignored and the TxD output is set to a 1.
<p>NOTE Command does not affect the CMR or the BRR.</p>		

The set/clear shift lock commands control the state of the internal shift lock flip flop. When shift lock is set, the keyboard controller encodes all key depressions as if the SHIFT input was asserted. The state of the shift lock flip flop is reflected in KSR5.

The set keyboard enable command enables the keyboard controller and sets KSR3 in the keyboard status register. The clear keyboard enable command resets KSR3 and disables key processing at the KRET input. The keyboard controller is not reset by this

command, and the current state of the keyboard (key depressions and latched key states) is preserved internally. When the keyboard is subsequently enabled, key processing resumes, old and new keys are debounced, and latched keys are encoded if there has been a change in their state.

**MASK PROGRAMMABLE OPTIONS**

Characteristics of certain portions of the PKCC are internally programmed by means of a read only memory. The items which can be programmed are:

- Key codes
- Auto-repeat keys
- Scan times, tone frequency, and tone duration
- Baud rates
- Interrupt vectors

Consult your local Signetics representative for costs, minimum quantities, and data submission requirements for customized versions of the PKCC.

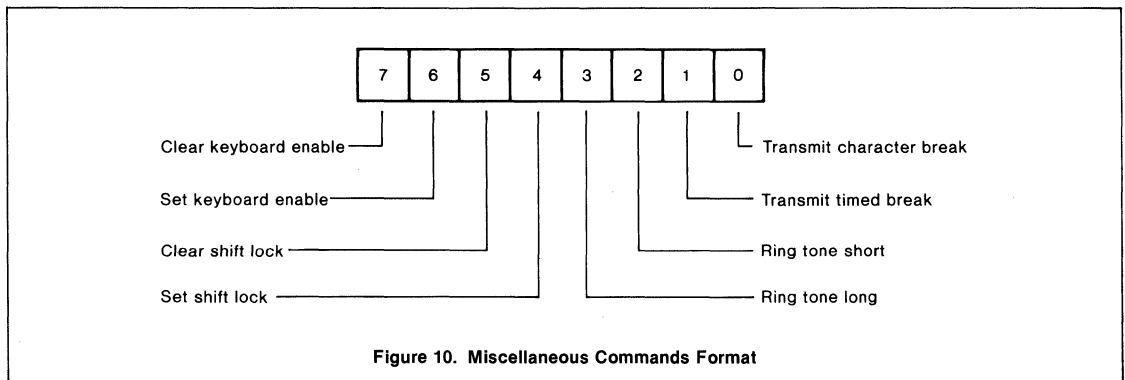

Figure 10. Miscellaneous Commands Format

# PROGRAMMABLE KEYBOARD AND COMM CONTROLLER (PKCC)    SCN2671

## ABSOLUTE MAXIMUM RATINGS<sup>1</sup>

PARAMETER	RATING	UNIT
Operating ambient temperature <sup>2</sup>	0 to +70	°C
Storage temperature	-65 to +150	°C
All voltages with respect to ground <sup>3</sup>	-0.5 to +6.0	V

2

## DC ELECTRICAL CHARACTERISTICS $T_A = 0^\circ\text{C}$ to $+70^\circ\text{C}$ , $V_{CC} = 5\text{V} \pm 5\%$ <sup>4,5,6</sup>

PARAMETER	TEST CONDITIONS	LIMITS			Unit
		Min	Typ	Max	
$V_{IL}$	Input low voltage			0.8	V
$V_{IH}$	Input high voltage				V
	XTAL1, XTAL2	4.0			V
	All other inputs	2.0			V
$V_{OL}$	Output low voltage			0.4	V
$V_{OH}$	Output high voltage (except $\overline{INTR}$ )				V
$I_{IL}$	Input leakage current	$I_{OL} = 1.6\text{mA}$ $I_{OH} = -100\mu\text{A}$ $V_{IN} = 0$ to $V_{CC}$			$\mu\text{A}$
	XTAL2/BRCLK		-100		$\mu\text{A}$
	All other inputs			10	$\mu\text{A}$
$I_{LL}$	Data bus 3-state leakage current	$V_O = 0$ to $V_{CC}$		10	$\mu\text{A}$
$I_{CC}$	Power supply current			150	mA

## AC ELECTRICAL CHARACTERISTICS $T_A = 0^\circ$ to $+70^\circ\text{C}$ , $V_{CC} = 5\text{V} \pm 5\%$ <sup>4,5,6</sup>

PARAMETER	TEST CONDITIONS	LIMITS			UNIT
		Min	Typ	Max	
Read timing <sup>7</sup>					
$t_{AS}$	Address setup to $\overline{RD}$	50			ns
$t_{CS}$	$\overline{CE}$ setup to $\overline{RD}$	50			ns
$t_{PW}$	$\overline{RD}$ pulse width	250			ns
$t_{AH}$	Address hold from $\overline{RD}$	20			ns
$t_{CH}$	$\overline{CE}$ hold from $\overline{RD}$	0			ns
$t_{DD}$	Data delay for read			200	ns
$t_{DF}$	Data bus floating time for read			100	ns
$t_{AD}$	Access delay from any read to next read or write	10			ns
		250			ns
Write timing <sup>8</sup>					
$t_{AS}$	Address setup to $\overline{WR}$	50			ns
$t_{CS}$	$\overline{CE}$ setup to $\overline{WR}$	50			ns
$t_{PW}$	$\overline{WR}$ pulse width	250			ns
$t_{AH}$	Address hold from $\overline{WR}$	20			ns
$t_{CH}$	$\overline{CE}$ hold from $\overline{WR}$	0			ns
$t_{DS}$	Data setup	100			ns
$t_{DH}$	Data hold	10			ns
$t_{AD}$	Access delay from any write to next read or write				ns
		250			ns
$t_{AD}$	Access delay from reset command to next read or write				ns
		1.0			$\mu\text{s}$

### NOTES

- Stresses above those listed under Absolute Maximum Ratings may cause permanent damage to the device. This is stress rating only and functional operation of the device at these or at any other condition above those indicated in the operation section of this specification is not implied.
- For operating at elevated temperatures, the device must be derated based on  $+150^\circ\text{C}$  maximum junction temperature.
- This product includes circuitry specifically designed for the protection of its internal devices from damaging effects of excessive static charge. Nonetheless, it is suggested that conventional precautions be taken to avoid applying any voltages larger than the rated maxima.

- Parameters are valid over operating temperature range unless otherwise specified.
- All voltage measurements are referenced to ground ( $V_{SS}$ ). All input signals swing between 0.4V and 2.4V with a transition time of 20ns maximum and time measurements are referenced at input voltages of 0.8V, 2.0V and at output voltages of 0.8V, 2.0V as appropriate, unless otherwise specified.
- Typical values are at  $+25^\circ\text{C}$ , typical supply voltages and typical processing parameters.
- See figure 11.
- See figure 12.

# PROGRAMMABLE KEYBOARD AND COMM CONTROLLER (PKCC)    SCN2671

## AC ELECTRICAL CHARACTERISTICS (Cont.)

PARAMETER	TEST CONDITIONS	LIMITS			UNIT
		Min	Typ	Max	
Interrupt acknowledge timing <sup>9</sup>					
t <sub>PWI</sub> INTA pulse width		300			ns
t <sub>DDI</sub> Data delay time for interrupt vector	C <sub>L</sub> = 150pF			250	ns
t <sub>DFI</sub> Data bus floating time after INTA	C <sub>L</sub> = 150pF	10		100	ns
t <sub>ADI</sub> INTA to INTA access delay		300			ns
INTR reset timing <sup>10</sup>					
t <sub>RI</sub> INTR delay from: Read RxHR (RxRDY) Read KHR (KRDY) Reset commands (KOVr,KERR,BREAK) Load TxHR (TxEMT,TxRDY) Mask bit reset				400 400 450 400 300	ns ns ns ns ns
Keyboard timing <sup>11</sup>					
f <sub>KCLK</sub> KCLK frequency			409		kHz
t <sub>KBD</sub> KR <sub>i</sub> , KC <sub>i</sub> to KRET sample delay: FAST SCAN SLOW SCAN		12.0 55.0			μs μs
t <sub>POS</sub> Scan time per matrix position: FAST SCAN SLOW SCAN			20 80		μs μs
t <sub>KRD</sub> KDRES delay from KCLK	C <sub>L</sub> = 150pF			400	ns
t <sub>KRH</sub> KDRES hold from KCLK	C <sub>L</sub> = 150pF			400	ns
t <sub>HYS</sub> HYS delay from KCLK	C <sub>L</sub> = 150pF			600	ns
t <sub>RCD</sub> KR <sub>i</sub> , KC <sub>i</sub> delay from KCLK	C <sub>L</sub> = 150pF			400	ns
UART timing <sup>12</sup>					
t <sub>RXS</sub> RxD setup time		200			ns
t <sub>RxH</sub> RxD hold time		200			ns
t <sub>TxD</sub> TxD delay from falling edge of TxC	C <sub>L</sub> = 150pF			300	ns
t <sub>TCS</sub> Skew between TxD transition and falling edge of TxC output	C <sub>L</sub> = 150pF		0		ns
t <sub>BRH</sub> XTAL1 clock high <sup>13</sup>		70			ns
t <sub>BRL</sub> XTAL1 clock low <sup>13</sup>		70			ns
f <sub>BRG</sub> BRG input frequency		1.0	4.9152	5.075	MHz
f <sub>R/T</sub> TxC or RxC input frequency	Clock rate factor = 16X, 32X, 64X			1.3	MHz
f <sub>R/T</sub> TxC or RxC input frequency	Clock rate factor = 1X			1.0	MHz
t <sub>R/TH</sub> TxC or RxC clock high		350			ns
t <sub>R/TL</sub> TxC or RxC clock low		350			ns

## NOTES

9. See figure 13.
10. See figure 14.
11. See figure 15 and 16.
12. See figure 17, 18, and 19.
13. See figures 20 and 21 for XTAL1, XTAL2 connections for driving XTAL2 with an external clock. Input levels for XTAL1 and XTAL2 are V<sub>IL</sub> ≤ 0.8V, V<sub>IH</sub> ≥ 4.0V, and t<sub>BRL</sub> and t<sub>BRH</sub> are measured at these levels.

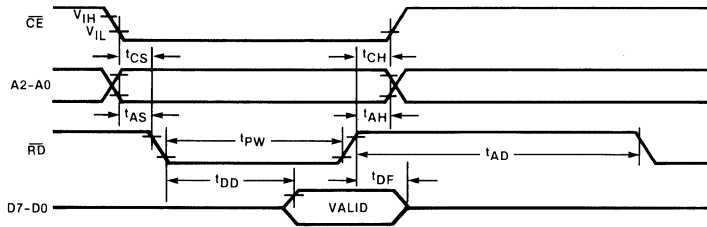

Figure 11. Read Timing

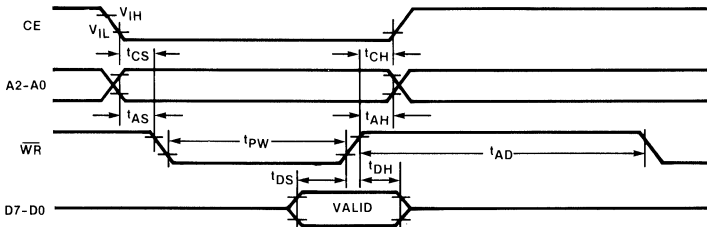

Figure 12. Write Timing

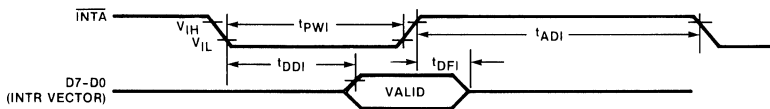
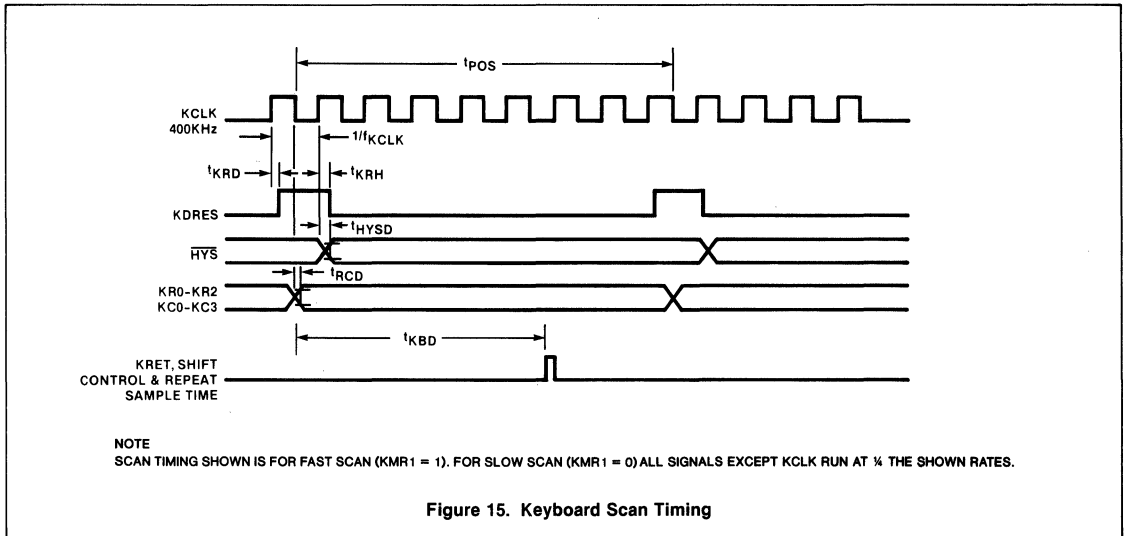
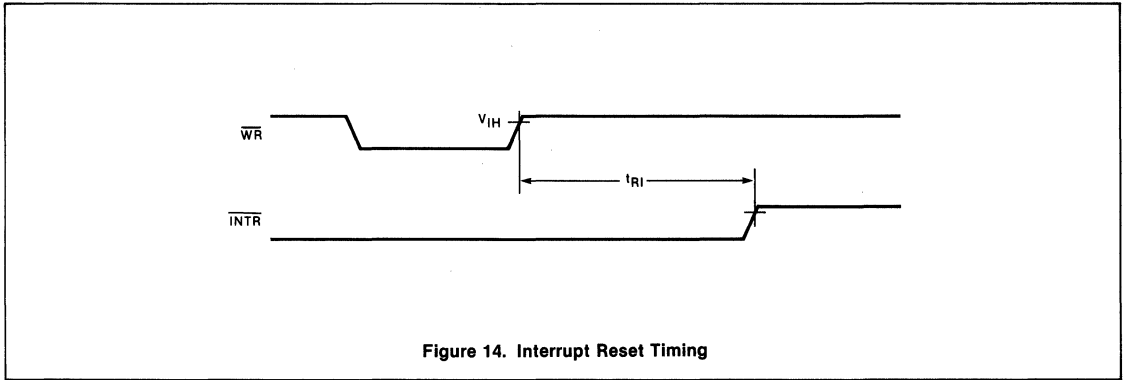

Figure 13. Interrupt Acknowledge Timing

**PROGRAMMABLE KEYBOARD & COMM CONTROLLER (PKCC)**

**SC2671**



**PROGRAMMABLE KEYBOARD AND COMM CONTROLLER (PKCC) SCN2671**

**2**

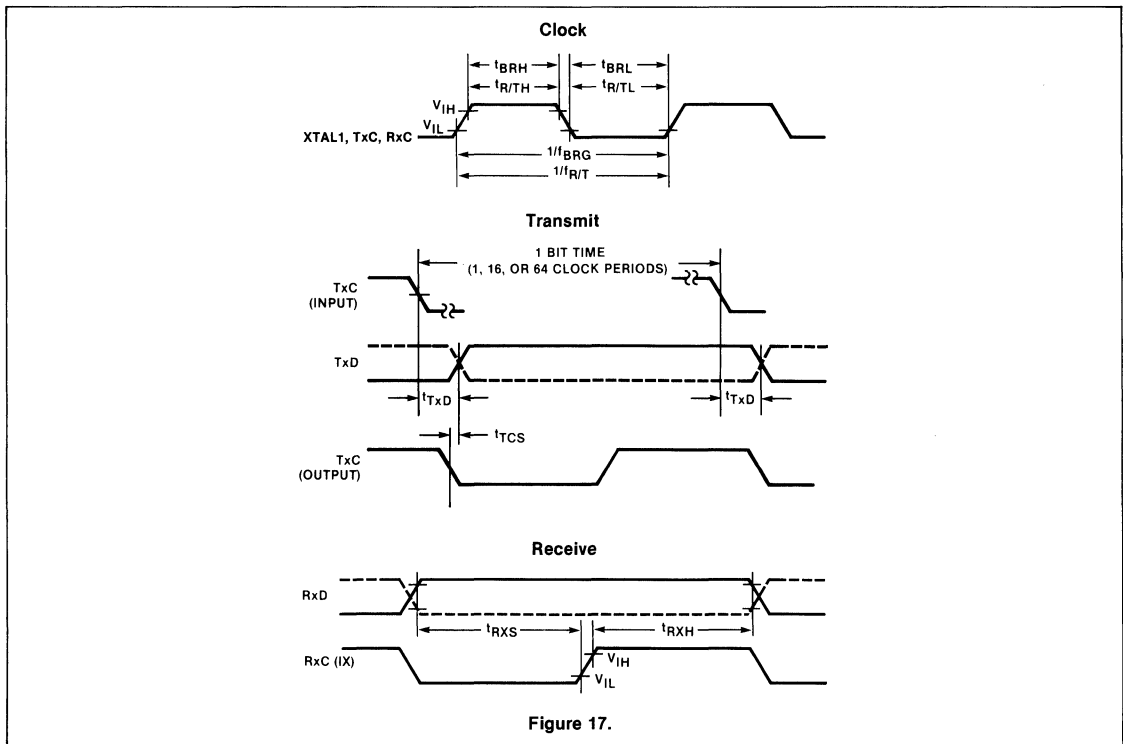
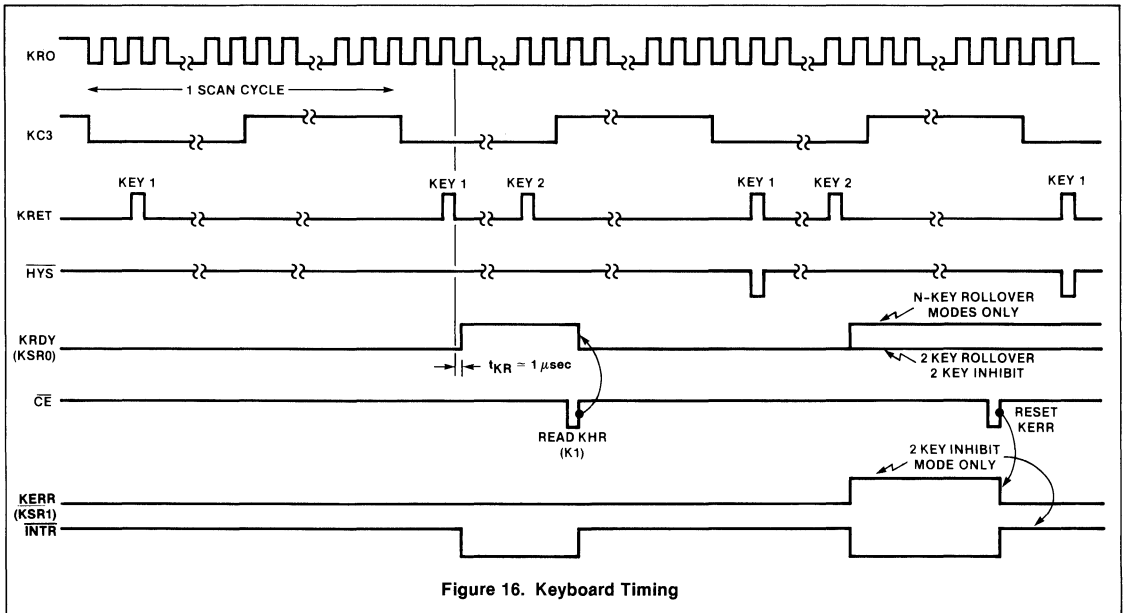

**PROGRAMMABLE KEYBOARD AND COMM CONTROLLER (PKCC) SCN2671**

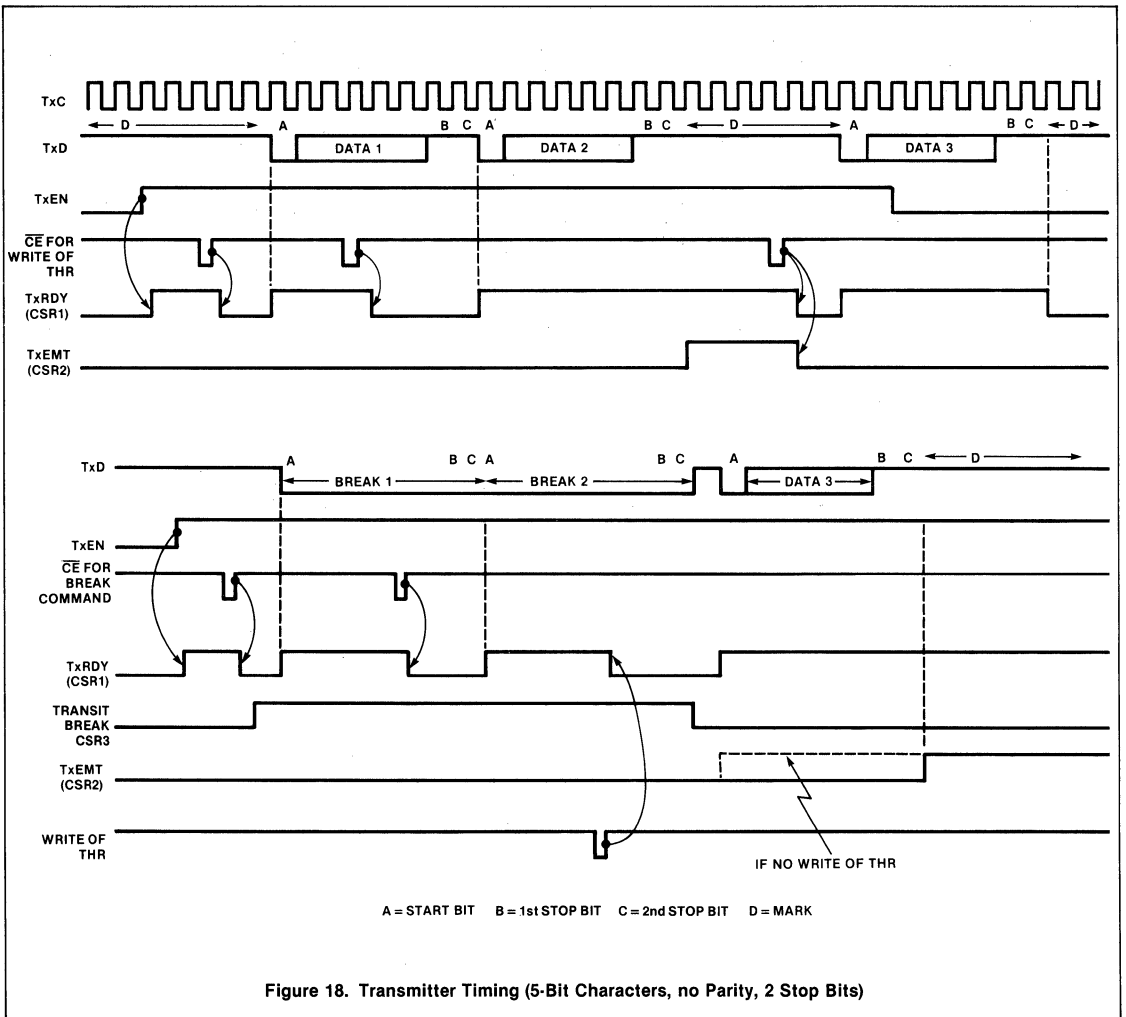

**PROGRAMMABLE KEYBOARD AND COMM CONTROLLER (PKCC) SCN2671**

**2**

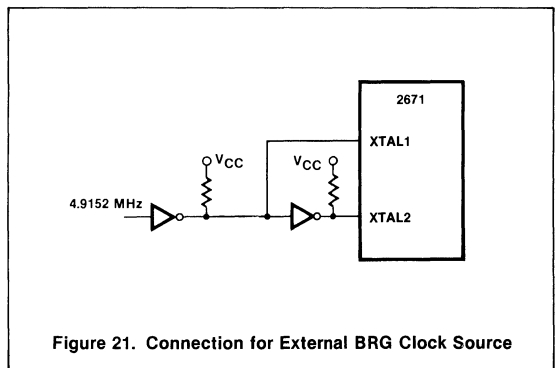
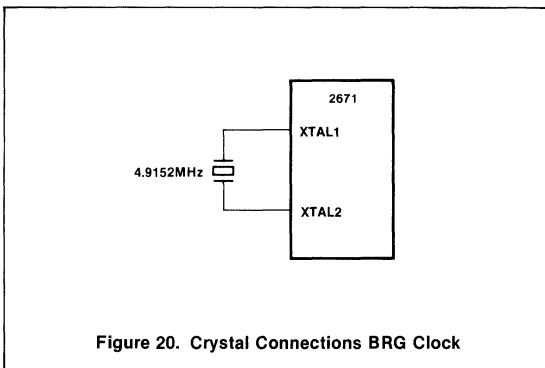
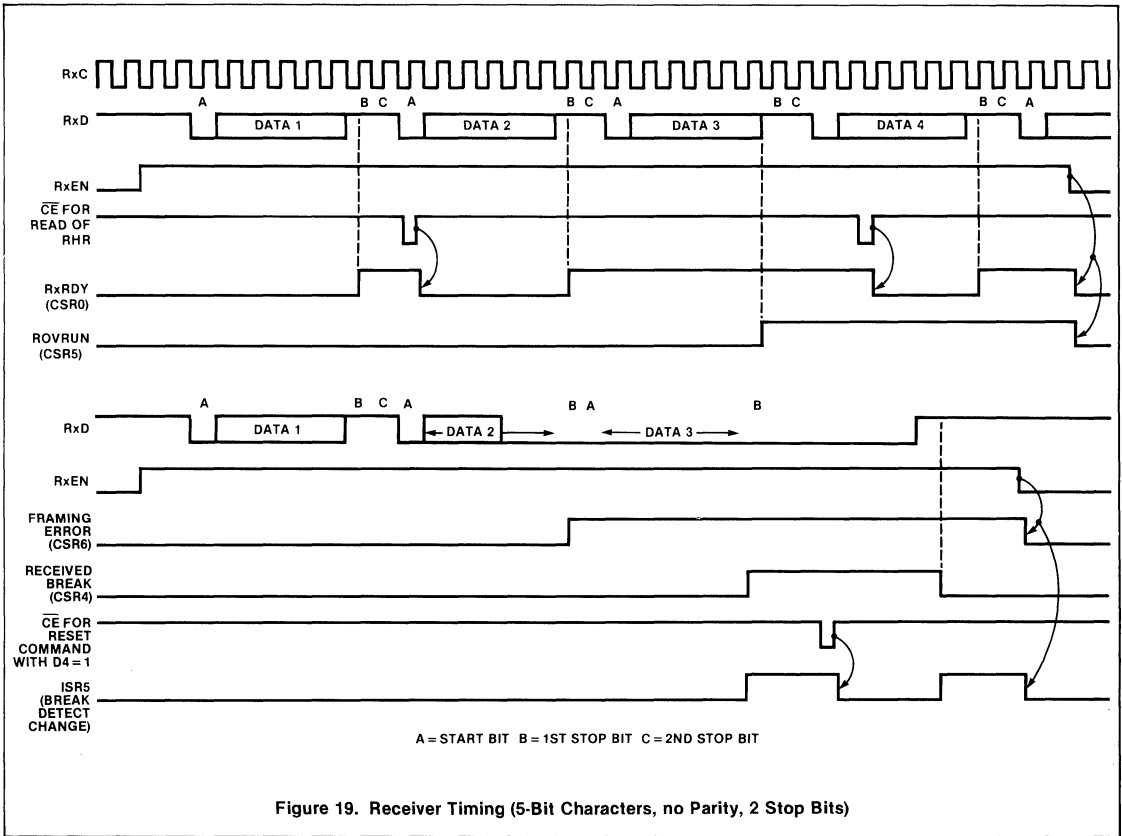

## PROGRAMMABLE KEYBOARD AND COMM CONTROLLER (PKCC) SCN2671

Table 7 REGISTER FORMAT SUMMARY

	7	6	5	4	3	2	1	0		
	Test mode		Rollover modes		Keyboard	Auto repeat		Tone select		
KMR	1 = Enable	00 = N-key with latched keys		0 = Encoded	0 = Disable		Key Matrix Size	0 = 1kHz		
	0 = Disable	01 = N-key 10 = Two keys 11 = Two key inhibit		1 = Non encoded	1 = Enable			Scan Time	1 = 2kHz	
						KMR2	KMR1			
						0	0	128	10ms	
					0	1	128	2.5ms		
					1	0	80	6.4ms		
					1	1	80	1.6ms		
KSR	CONTROL	SHIFT	SHIFT LOCK	REPEAT	Keyboard Enabled	KOVR	KERR	KRDY		
	Operating Mode		Parity	Parity Mode		Stop Bits	Character Length			
	00 = Normal 01 = Auto echo 10 = Local loopback 11 = Remote loopback		0 = Odd/force 0  1 = Even/force 1	00 = With parity 01 = Force parity 10 = No parity 11 = Not allowed		0 = Two  1 = One	00 = 8 01 = 5 10 = 6 11 = 7			
	CMR	Tx Clock source	Rx Clock source	Clock rate factor for external clocks		Baud rate select (BRR3 - BRRO in hex)				
0 = External  1 = Internal (BRG)		0 = External  1 = Internal (BRG)	00 = 16X 01 = 32X 10 = 64X 11 = 1X  For internal clocks these bits specify the output frequency on pins 34 and 35 (table 4).		0 = 50 1 = 110 2 = 134.5 3 = 150	4 = 200 5 = 300 6 = 600 7 = 1050	8 = 1200 9 = 1800 A = 2000 B = 2400	C = 4800 D = 9600 E = 19200 F = 38400		
								(BRCLK = 4.9152MHz)		
CSR	Parity error	Framing error	Overrun error	Received break	Transmit break	TxE <sub>MT</sub>	TxRDY	RxRDY		
	IMR/ISR	TxRDY	TxE <sub>MT</sub>	BREAK CHANGE	XINT	KERR	KRDY	KOVR	RxRDY	
		Reset Command Format	00X = No effect 010 = Set Rx <sub>E</sub> 011 = Reset Rx <sub>E</sub> 100 = Set Tx <sub>E</sub>	101 = Reset Tx <sub>E</sub> 110 = Set Tx <sub>E</sub> and Rx <sub>E</sub> 111 = Communications reset	Break detect change reset	Communications error reset	KOVR reset	KERR reset	Keyboard reset	
			Miscellaneous Commands Format	Clear keyboard enable	Set keyboard enable	Clear shift lock	Set shift lock	Ring tone long	Ring tone short	Transmit timed break