

MARK II KEYBOARDS



- **SNAP ACTION KEYS**
- **INTEGRATED CIRCUITRY**
- **FLEXIBILITY**
- **ELECTRONIC INTERLOCKS**
- **RELIABILITY**

The Controls Research Mark II Keyboard is the most advanced systems concept available today. It is engineered to provide the simplest and most efficient link available between the operator and the computer or industrial control system.

Magnetic snap action of the Mark II Keyboard is provided through the use of CRC 02 keyboard switches. This unique concept in key design allows complete flexibility in key arrangement. The custom keyboard is now economically feasible.

The use of integrated circuitry in the Mark II Keyboard heralds the beginning of a new generation of highly reliable and extremely versatile encoding systems. Through the use of integrated circuits, electronic interlocks, variable strobing, and high speed bounce-free outputs are available, which are compatible with modern computer and industrial control systems.





KEYBOARD OPTIONS

KEYS AND ARRANGEMENTS

Any specified keyboard with any number of keys.

No restrictions on key placement except $\frac{3}{4}$ inch minimum center-to-center spacing.

CODING OPTIONS

STANDARD: ASCII, 7 Bit + parity Bit, 8 Bit total.

OPTIONAL: BCD or other codes to customer specification with any number of outputs.

OUTPUT OPTIONS

1. Single line output from glass reeds (voltage and current supplied by user)
2. Binary coded single line output
3. Binary coded "Bounce-Free" transistor output with electronic interlock.
4. Binary coded "Bounce-Free" buffered integrated circuit output with electronic interlock.
5. Binary coded "Contact Closure" output with electronic interlock.

Voltage and current supplied by user on all encoded keyboards - 40V & 50MA max.

Options 3, 4, & 5 require a D.C. voltage of 4.0 - 6.0 V at 100 MA in addition to other voltages as required by specific applications.

SPECIAL OPTIONS

Strobe Signal

Delay variable from 100 NSEC to 500 MSEC

Width variable from 250 NSEC to 500 MSEC

Output Reset

Internally variable or externally controlled

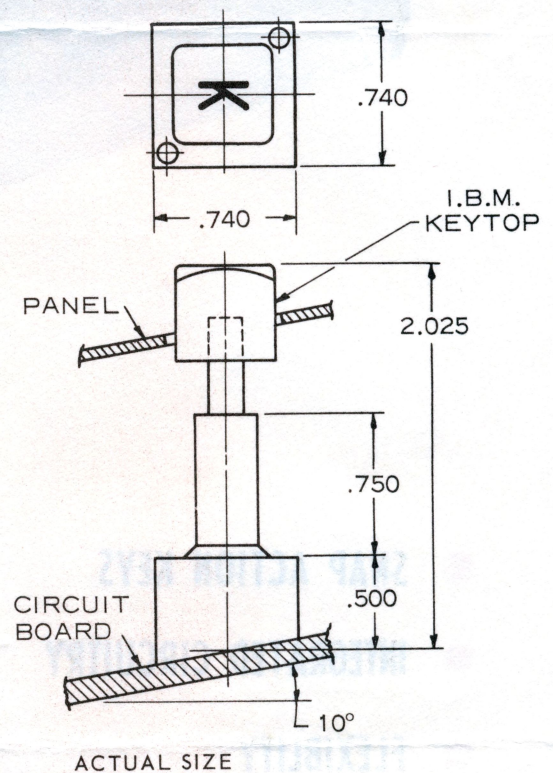

KEY SPECIFICATIONS

Snap Force:	3 oz.
Return Force:	1 oz.
Contact Life:	1,000,000 cycles
Contact Rating:	100 mills max.
Contact Bounce:	$\frac{1}{2}$ millisecond
Contacts:	Dry reed switch
Shaft Dim.:	.040 x .187
Shaft Material:	301 full hard stainless
Housing:	Noryl Plastic
Return Spring:	302 stainless
Mounting:	(2) 2-56 machine screws
Travel:	.156



Date _____

Quote Req'd by _____

Controls Research Corporation P.O. Box No. 5037 11762 Western St., Garden Grove, California

■ SPECIALIZING IN PRECISION SWITCHING DEVICES

Telephone (714) 892-9415
(714) 537-1900

Your Name _____ Company _____

Address _____ Phone _____

City _____ State _____ Zip _____

Keyboard Requirements

1. Supply quote on quantities _____
(circle quantity representing normal buy)
to be delivered over a period of _____ months, starting _____.
2. Total number of keys per keyboard _____.
3. Unit is to be panel mounted _____ or self contained _____.
4. Keys are on .750 centers _____ or _____ centers. (if possible send dwg)
5. Keytops to be IBM in size and color _____ or _____ (send dwg)
6. Output requirement will be:
Single line outputs from reed switches _____ keys.
Binary coded single line outputs _____ keys.
7. Output code is _____ bit ASC II or _____ (if possible send chart)
8. Electronic interlock is required _____ not required _____.
Interlock to be reset externally _____ or Internally _____.
9. Output logic levels are _____ Vdc ± _____ Vdc = logical "0"
_____ Vdc ± _____ Vdc = logical "1"
10. Output current requirements are _____ mAdc "forcing" current.
_____ mAdc "sinking" current.
11. External voltages are _____ Vdc at _____ mA. None _____
_____ Vdc at _____ mA.
12. Output reset is required and is to be externally controlled _____,
or internally controlled after _____ msec, _____ µsec.
13. Strobe output is required _____. (Complete timing diagram below)

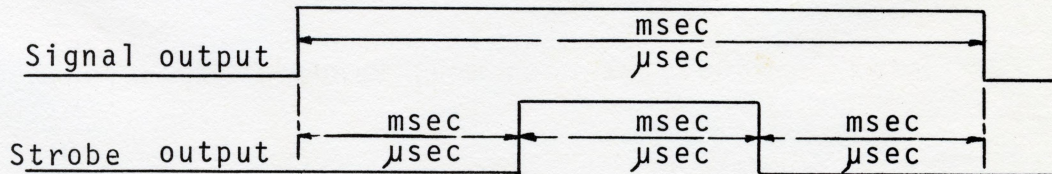

Please add any special requirements you may have on back of this sheet.

THANK YOU