

CUSTOM MADE HIGH-PROFILE KEYBOARD

KBS01 Series

■ Features

1. A soft, linear feeling is obtained through use of rubber chips (J-F0430).
2. Single keys can be replaced at a single touch, making free layout rearrangement possible.

■ Basic Structure

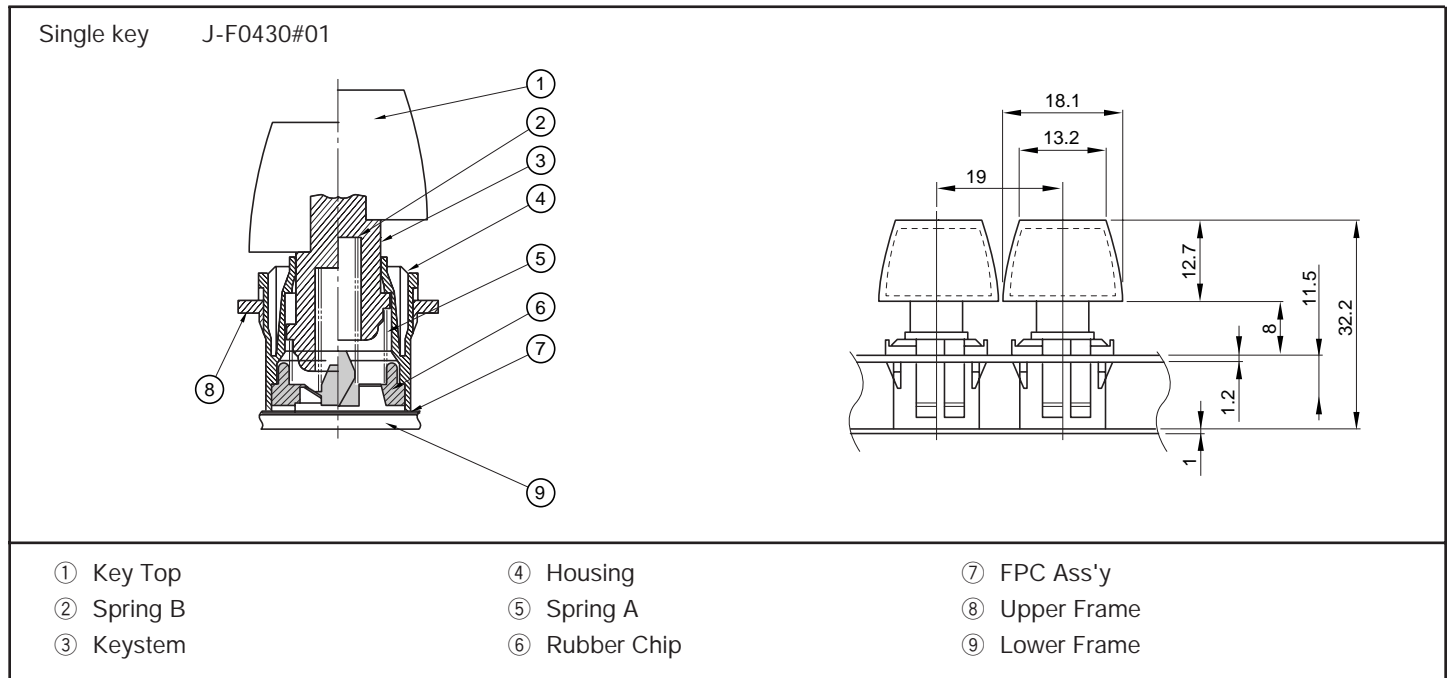

■ Specifications

Operating Force	90±30gf (0.883±0.294N)
Key Stroke	3mm
Maximum Rating	2mA 12V DC
Contact Resistance	500Ω max.
Operating Life	1 x 10 ⁷ cycles

KBS01 Series

■ Key Switch Assembly Chart

Classification	① Cap	② Key Top	③ Key Switch	④ Dummy Switch
1X1 Unit 	S-Z0513-71#01	S-Z0512-70#02	J-F0430 #01	-
Q'ty	1	1	1	-
2X1 Unit 	S-Z0513-75#01	S-Z0512-74#02	J-F0432 #01	J-F0434 #01
Q'ty	1	1	1	1
2X2 Unit 	S-Z0513-77#01	S-Z0512-76#02	J-F0431 #01	J-F0434 #01
Q'ty	1	1	1	1