

# DC-50 SERIES KEY SWITCHES

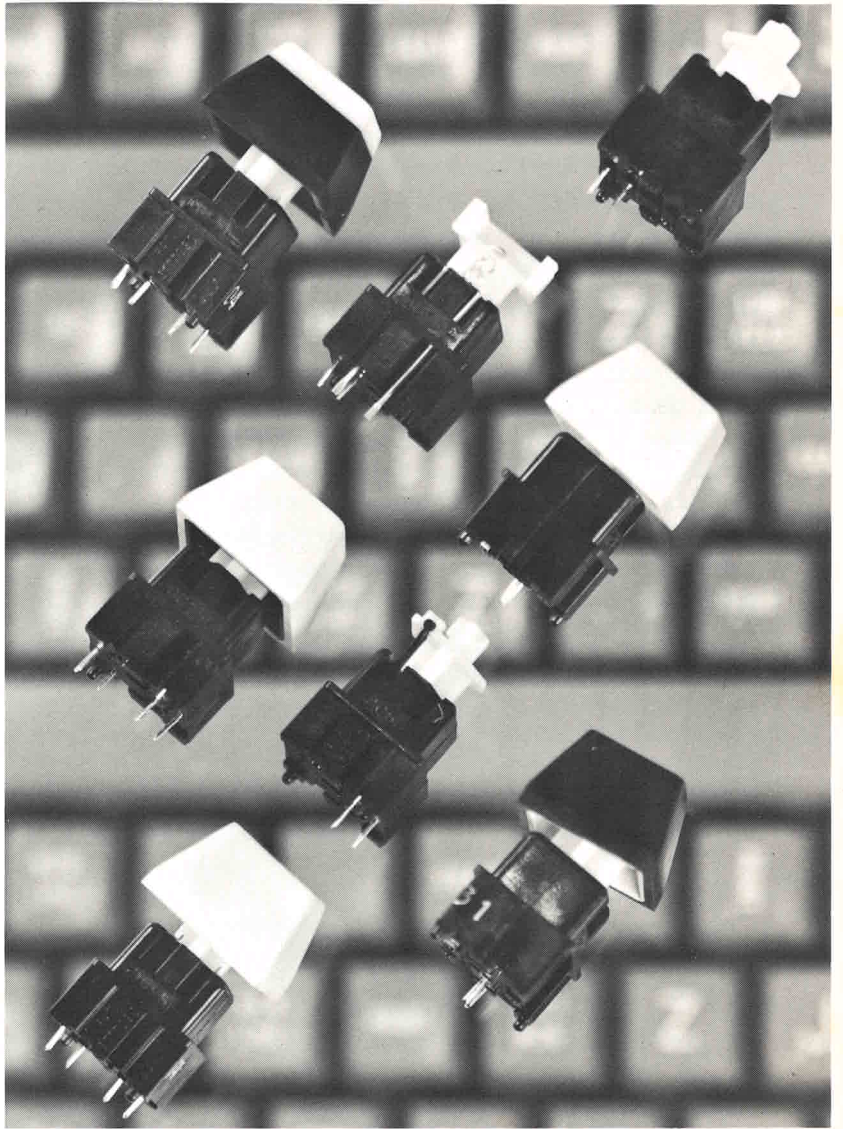

## WITH FEATURES FOR ALL THE KEY DECISION MAKERS

**THE DESIGN ENGINEER** — Complete keyboard design flexibility . . . six standard configurations . . . single or double pole, lighted or unlighted, momentary or alternate action . . . optional 12° offset key stem . . . extensive key cap library . . . relegendable key caps.

**THE PRODUCTION MANAGER** — Increased productivity . . . minimum production floor rejects . . . 100% factory tested . . . rigid quality control . . . pre-tinned wave solderable leads . . . standoff mounting permits de-fluxing.

**THE PURCHASING AGENT** — Greatly reduced price for the high performance features of expensive reed or solid state switches . . . off-the-shelf delivery.

**THE MARKETING MANAGER** — A switch that helps sell the end product . . . typewriter feel . . . built-in hysteresis prevents accidental double character . . . attractive low profile configuration.

**THE FIELD SERVICE MANAGER** — Reliable performance and low maintenance . . . equipment lifetime warranty . . . 100,000,000 cycle life.

# Datanetics

## GENERAL DESCRIPTION

The DC-50 Series line of quality key switches offers at a substantially lower price the same desirable features previously associated only with expensive reed or solid state switches. Such features include tease-proof action, tactile feel, exceptional reliability, and a virtually unlimited operating life.

A key factor in this design achievement is Datanetics' exclusive elastic diaphragm switch element which encloses two gold-plated switching contacts in a mylar and stainless steel sandwich, thus protecting the contacts from damage and environmental contamination. This patented arrangement contributes significantly to the DC-50's guaranteed minimum operating life of 100,000,000 closures and enables the achievement of an excellent cost/effectiveness ratio as compared to any other switch on the market.

Throughout the entire DC-50 line, the "human factors" aspect of design is optimized. Built-in hysteresis all but eliminates accidental double character entry. This "non-teasability" factor is inherent in magnetically activated reed switches and is electrically built into some of the costly solid state switches. In the DC-50 Series, it is

economically achieved through Datanetics' innovative actuating mechanism. As illustrated by the force-displacement diagram below, the switch "makes" when the key stem is depressed to .110 inches. The key stem must then withdraw 40 thousandths of an inch to .070 inches before the closure is broken. Hysteresis is an absolute necessity for all rapid data entry uses and has been found to be highly desirable in calculators and less demanding applications as well.

The diagram below also illustrates how the unique mechanism supplies sufficient tactile feedback to tell the operator the instant of make and break while simulating the familiar feel of an electric typewriter keyboard. The overall design assures minimal wobble, negligible bounce of less than 2 ms, and smooth, free action under the worst side loading conditions.

The DC-50 is available in six fully compatible configurations to allow high flexibility in keyboard design. Options include single or double pole, lighted or unlighted, momentary or alternate action, and a 12° offset key stem for stepped keyboards.

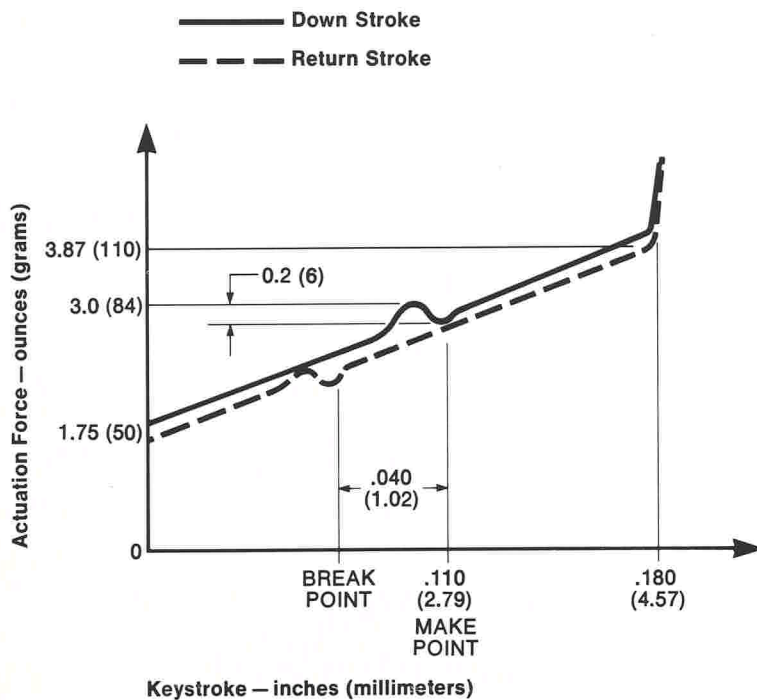

**FORCE / STROKE DIAGRAM**

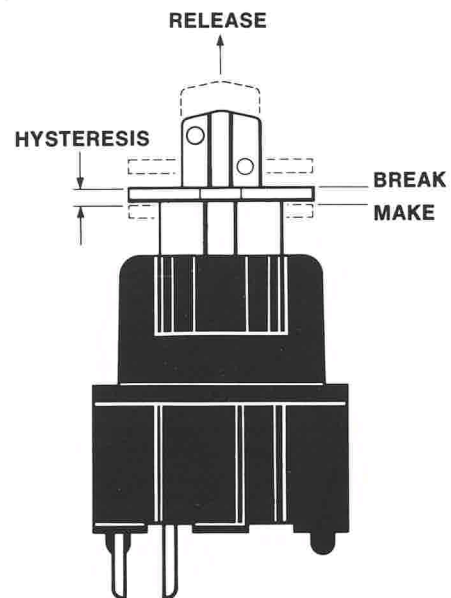

**KEY SWITCH HYSTERESIS**

# DC-50 SERIES KEYSWITCH SPECIFICATIONS

## GENERAL SPECIFICATIONS

The following specifications apply to all DC-50 models. Refer to SPECIFIC SWITCH MODEL CONFIGURATION and OPTIONS for individual model data and standard options.

### Electrical

Contact Ratings (resistive load)	
Volt-Amp Range	0.3 to 50 MVA
Current Range	0.3 to 10 ma
Voltage Range	0.5 to 30 VDC
Contact Resistance	0.200 ohm maximum (0.050 ohm typical)
Contact Bounce	2.0 ms maximum (0.5 ms typical)
Insulation Resistance	100 megohms minimum @ 100 VDC (1,000 megohms typical)
Capacitance	10 pf maximum @ 1 KHz (5 pf typical)

### Mechanical

Contacts	Gold-plated copper alloy
Minimum Key Switch Spacing	0.625 in. (15.87 mm)
Pretravel (to make point)	0.110 ± 0.015 in. (2.8 ± 0.38 mm)
Total Travel	0.180 ± 0.010 in. (4.57 ± 0.25 mm)
Release Point (above make point)	0.040 ± 0.010 in. (1.01 ± 0.25 mm)
Operating Life	100,000,000 closures minimum

### Environmental

Operating Temperature	+32° to +140°F (0° to +60°C)
Storage Temperature	-32° to +160°F (-35° to +71°C)
Relative Humidity	5% to 95% non-condensing
Vibration	10-55Hz @ 0.06 in. (1.5 mm) displacement

### Physical

Weight	0.17 oz. (5 gm) maximum
Terminals	Pre-tinned; 0.160 in. (4.06 mm) nominal
Termination Method	Wave solderable at 530°F (278°C) maximum (for 10 sec. maximum) into 0.046 in. (1.7 mm) diameter printed circuit board hole

## SPECIFIC SWITCH MODEL CONFIGURATION

### DC-51-01—Single Pole, Momentary Action Switch

Contact Arrangement	Single pole, normally open (Form A)
Operating Force	3 ± 0.5 oz. (84 ± 15 gm)

### DC-51-03—Single Pole, Alternate Action Switch

Contact Arrangement	Single pole, normally open (Form A)
Travel to Latch Position	0.110 ± 0.01 in. (2.8 ± 0.38 mm)
Operating Force to Latch Position	4.5 ± 0.5 oz. (125 ± 15 gm)
Release Force	5.5 ± 0.5 oz. (155 ± 15 gm)

### DC-51-04—Double Pole, Momentary Action Switch

Contact Arrangement	Double pole, normally open (Form A)
Operating Force	4.5 ± 0.5 oz. (122 ± 15 gm)

### DC-51-41—Single Pole, Illuminated Momentary Action Switch

Contact Arrangement	Single pole, normally open (Form A)
Operating Force	3 ± 0.5 oz. (84 ± 15 gm)
Lamp	Replaceable T-1 wire terminal
Lamp Voltage	5 VDC
Lamp Current	115 ma

### DC-51-43—Single Pole, Illuminated Alternate Action Switch

Contact Arrangement	Single pole, normally open (Form A)
Travel to Latch Position	0.110 ± 0.01 in. (2.8 ± 0.38 mm)
Operating Force to Latch Position	4.5 ± 0.5 oz. (125 ± 15 gm)
Release Force	5.5 ± 0.5 oz. (155 ± 15 gm)
Lamp	Replaceable T-1 wire terminal
Lamp Voltage	5 VDC
Lamp Current	115 ma

### DC-51-44—Double Pole, Illuminated Momentary Action Switch

Contact Arrangement	Double pole, normally open (Form A)
Operating Force	4.5 ± 0.5 oz. (122 ± 15 gm)
Lamp	Replaceable T-1 wire terminal
Lamp Voltage	5 VDC
Lamp Current	115 ma

## OPTIONS

- 1) High Force Return Spring.
- 2) 12° Angled Key Stem for stepped keyboard application.
- 3) Extensive library of double shot key caps.
- 4) Relegendable key caps.

## DIMENSIONS

Dimensions shown in inches (millimeters)

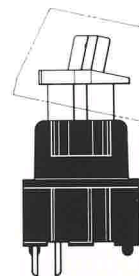
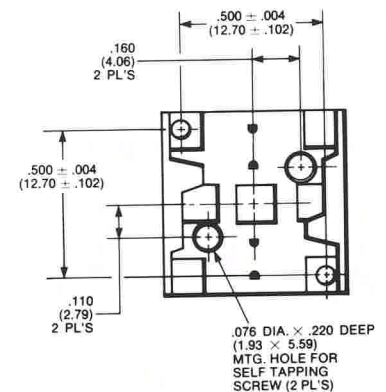
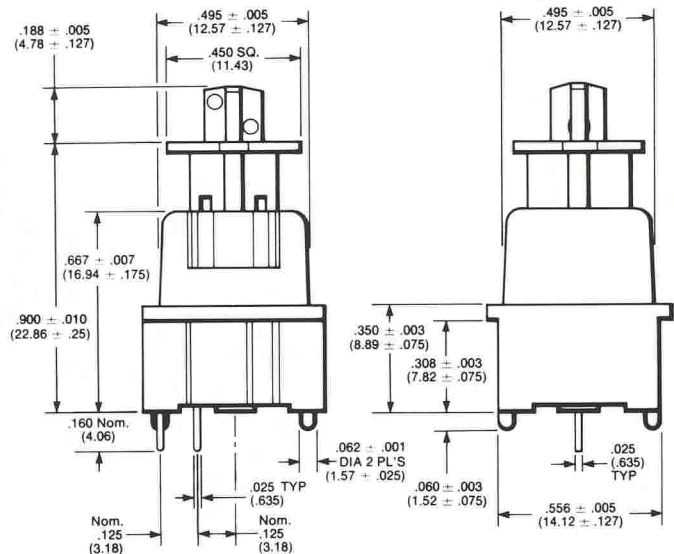
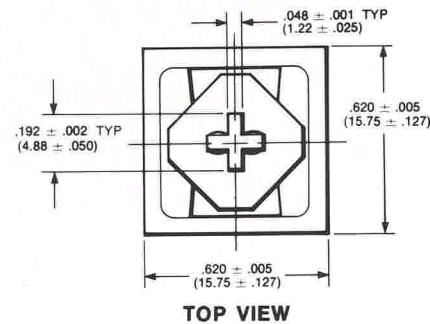

12° KEY STEM OPTION  
Actual Size

BOTTOM VIEW

## SWITCH MOUNTING

RECOMMENDED MOUNTING DIMENSIONS  
(DIMENSIONS NOM.)

### SINGLE POLE KEY SWITCH TOP VIEW OF CIRCUIT BOARD

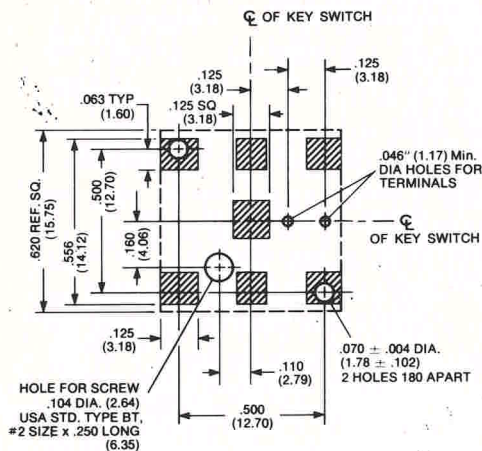

### DOUBLE POLE KEY SWITCH TOP VIEW OF CIRCUIT BOARD

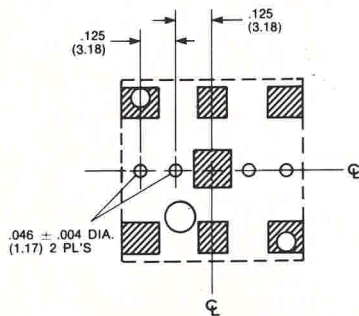

### LAMP TERMINAL LOCATIONS TOP VIEW OF CIRCUIT BOARD

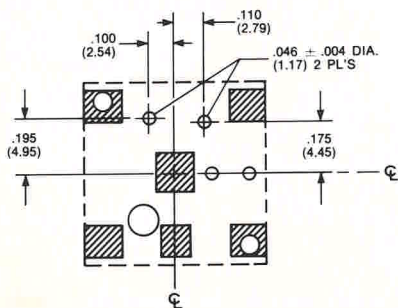

## APPLICATION AND ADDITIONAL INFORMATION

### WARRANTY

The DC-50 Series Key Switches\* are guaranteed by Datanetics to perform in accordance with all applicable specifications for the life of the equipment in which they are used. Datanetics will replace, F.O.B. Fountain Valley, California, at no cost to the user, any switch that fails to meet these criteria unless physical or electrical abuse is evident. (This warranty does not apply to the replaceable lamp in lighted switches.)

### MATERIALS

#### Housing

The switch housing is molded Noryl™, a thermoplastic selected for its excellent high-temperature characteristics.

#### Key Stem

Key stems are molded Delrin.™

The combination of key stem and housing (key stem guide) materials was selected for resistance to wear, high stability and smooth action.

#### Switch Element

The switch element, which encloses the switch contacts, is a mylar and stainless steel sandwich permanently bonded with thermo-activated adhesive to protect the switch contacts from dirt and environmental damage.

#### Switch Contacts

The switch contacts are cadmium copper alloy with gold-over-nickel plating.

#### Terminals

Terminals are gold-over-nickel plated copper, preformed for ease of insertion into a printed circuit board, and are pre-tinned for excellent solderability.

### ASSEMBLY

#### Switch Mounting

The mounting dimensions for each switch configuration are presented on this page. Mounting screws are USA standard type BT, #2 size x 0.250 inches (6.35 mm) maximum. Screw torque of 24 ± 4 inch-oz. is recommended. (Excessive torque may damage the switch.)

For flow soldering, screws should be stainless steel, chrome plated, or black oxidized steel.

The switch housing has molded-in standoffs in seven places, providing clearance to permit defluxing of the switch terminations. Consideration should be given, during printed circuit board layout, to assure that all switch standoffs are resting in the same plane. This will avoid stressing the switch housing, which could interfere with smooth switch operation or cause key cap misalignment.

#### Soldering

High-temperature materials allow flow soldering at a temperature of 530°F (287°C) for 5 seconds.

#### Cleaning

If a cleaning solvent is required, it is recommended that water, Isopropyl Alcohol, trichlorotrifluoroethane or Freon™ (T.F.) be used. Since many solvents are harmful to plastics, any variation from the recommended cleaning solvents should be used with extreme caution.

\*Patented